

**312-A & 312-8 Information List (1986)**

Wiring Diagram . . . . . 7-46

Circuit Diagrams

- Starter Motor Circuits . . . . . 7-47
- Spark Circuit . . . . . 7-48
- Charging Circuit . . . . . 7-48
- Gauge Circuit . . . . . 7-48
- Light Circuit . . . . . 7-49
- Oil Light Test Circuit . . . . . 7-49

Wiring Diagram

rev. 4-03

Wiring Diagram

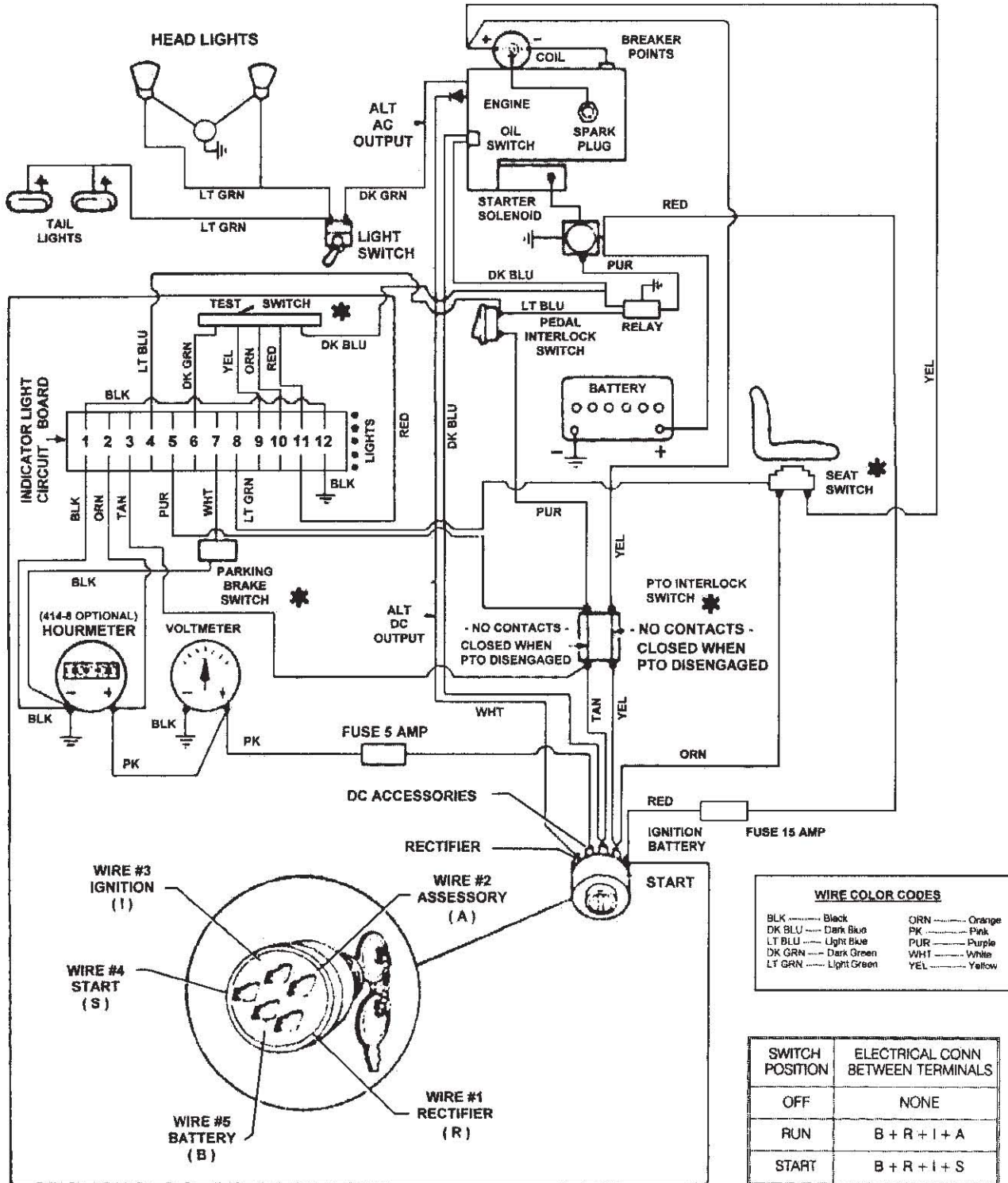

**WIRE COLOR CODES**

BLK	Black	GRN	Orange
DK BLU	Dark Blue	PK	Pink
LT BLU	Light Blue	PUR	Purple
DK GRN	Dark Green	WHT	White
LT GRN	Light Green	YEL	Yellow

SWITCH POSITION	ELECTRICAL CONN BETWEEN TERMINALS
OFF	NONE
RUN	B + R + I + A
START	B + R + I + S

**Starter Motor Circuit**  
(ignition switch in "start")

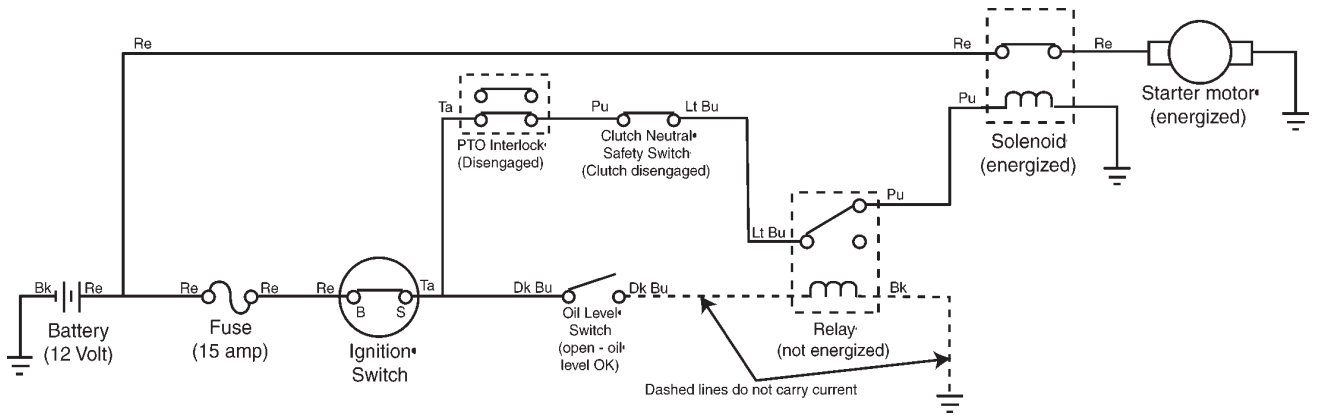

**Starter Motor Circuit**  
(ignition switch in "start" with low oil level)

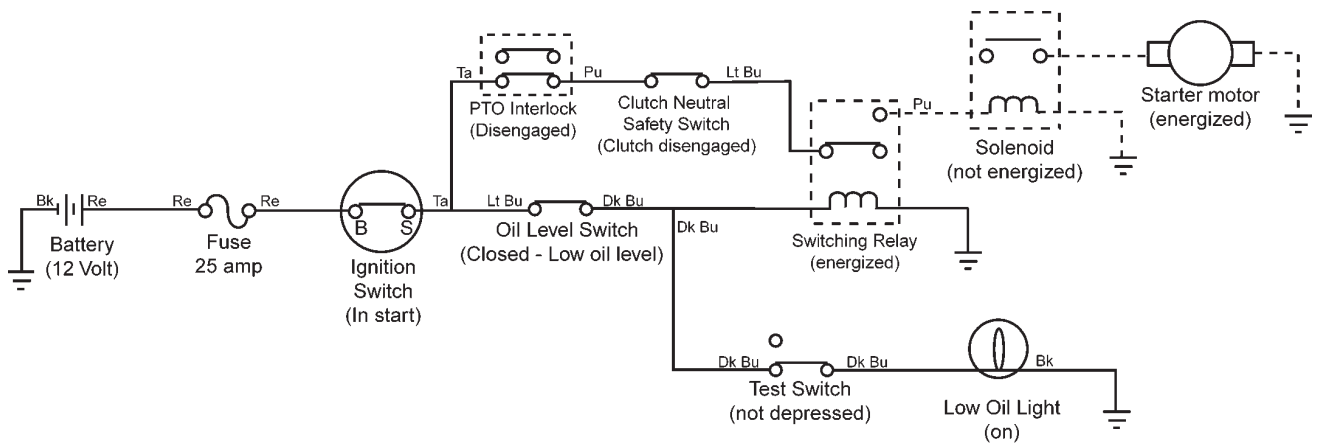

Legend	
Black*	Bk*
Blue*	Bu*
Brown*	Br*
Dark Blue*	Dk Bu*
Dark Green*	Dk Gr*
Green*	Gn*
Gray*	Gy*
Light Blue*	Lt Bu*
Orange*	Or*
Pink*	Pi*
Purple*	Pu*
Red*	Rd*
Tan*	Ta*
White*	Wh*
Yellow*	Ye*

**Spark Circuit**

*(ignition switch in "start")*

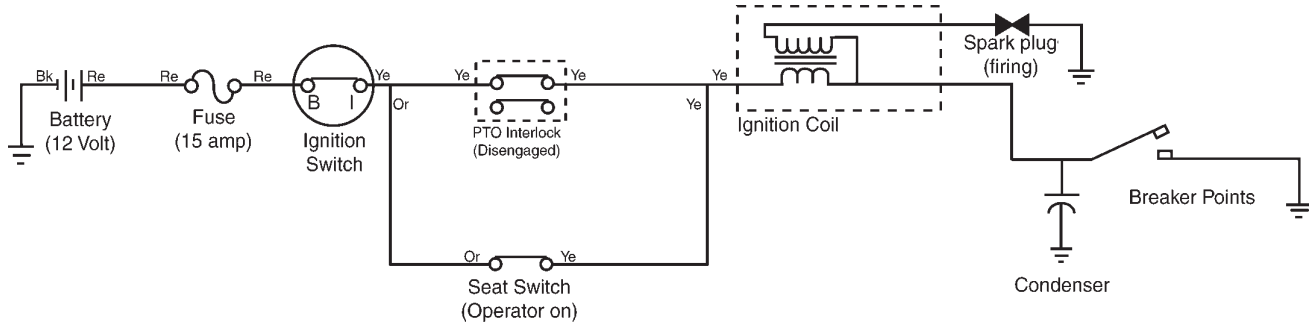

**Charging Circuit**

*(ignition switch in "run")*

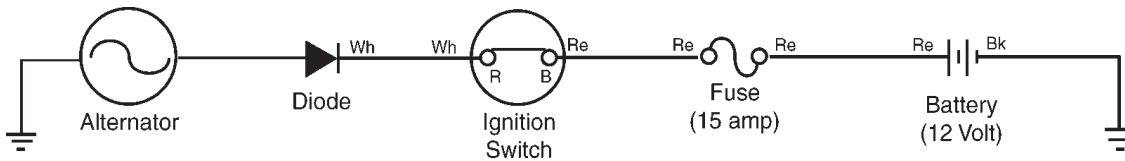

**Gauge Circuit**

*(ignition switch in "run")*

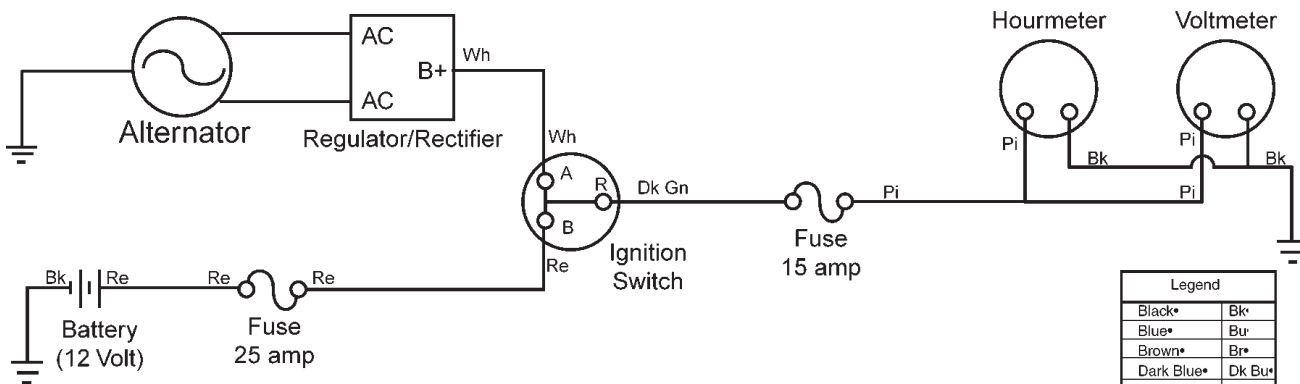

Legend	
Black*	Bk
Blue*	Bu
Brown*	Br
Dark Blue*	Dk Bu
Dark Green*	Dk Gn
Green*	Gn
Gray*	Gy
Light Blue*	Lt Bu
Orange*	Or
Pink*	Pi
Purple*	Pu
Red*	Rd
Tan*	Ta
White*	Wh
Yellow*	Ye

Circuits

**Light Circuit**  
(ignition switch in "run")

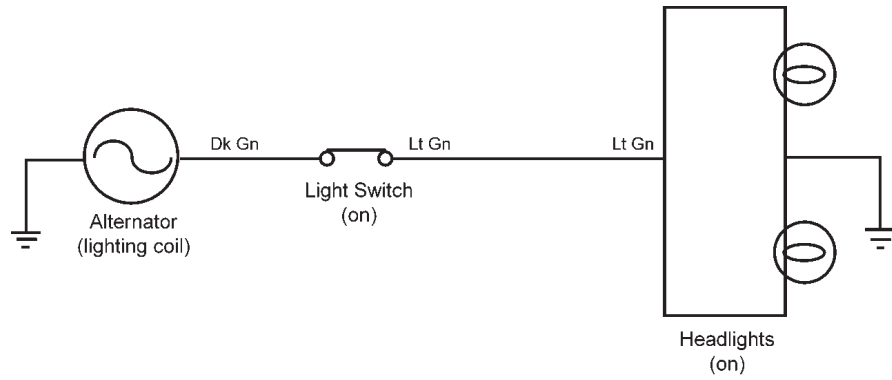

**Oil Light Test Circuit**  
(ignition switch in "run")

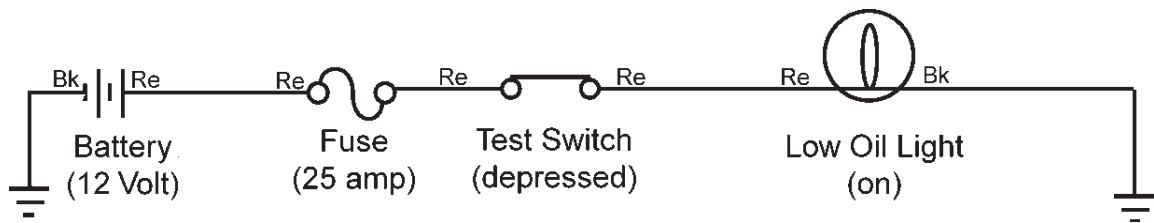

Legend	
Black*	Bk*
Blue*	Bu*
Brown*	Br*
Dark Blue*	Dk Bu*
Dark Green*	Dk Gn*
Green*	Gn*
Gray*	Gy*
Light Blue*	Lt Bu*
Orange*	Or*
Pink*	Pi*
Purple*	Pu*
Red*	Rd*
Tan*	Ta*
White*	Wh*
Yellow*	Ye*

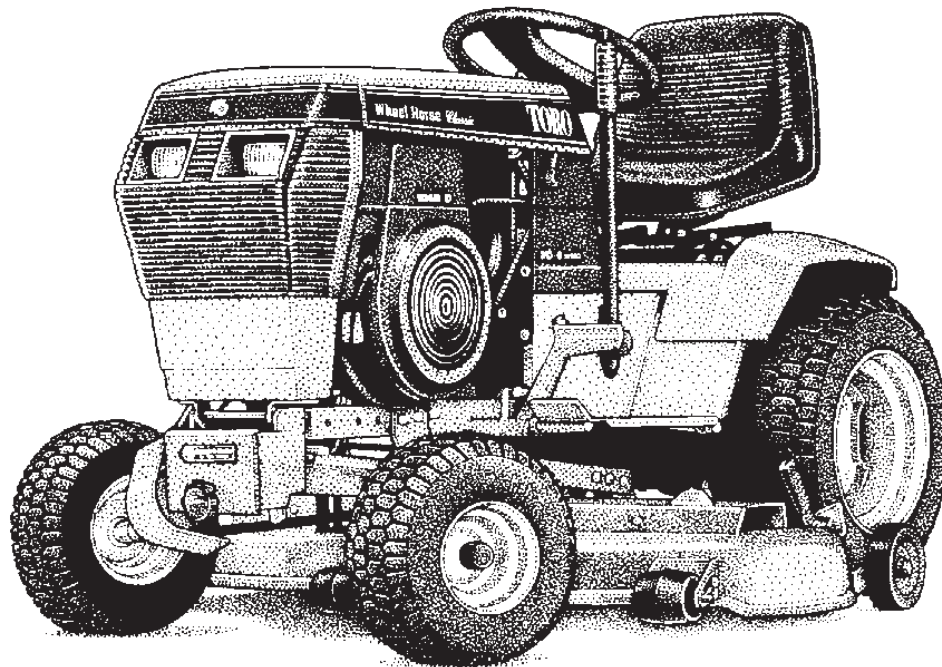

**312-8 Information List (1987 - 1988)**

Wiring Diagram . . . . . 7-34

Circuit Diagrams

    Starter Motor Circuit . . . . . 7-35

    Spark Circuit . . . . . 7-35

    Charging Circuit . . . . . 7-36

    Gauge Circuit . . . . . 7-36

    Light Circuit . . . . . 7-36

    Oil Circuit . . . . . 7-37

Wiring Diagram

Wiring Diagram

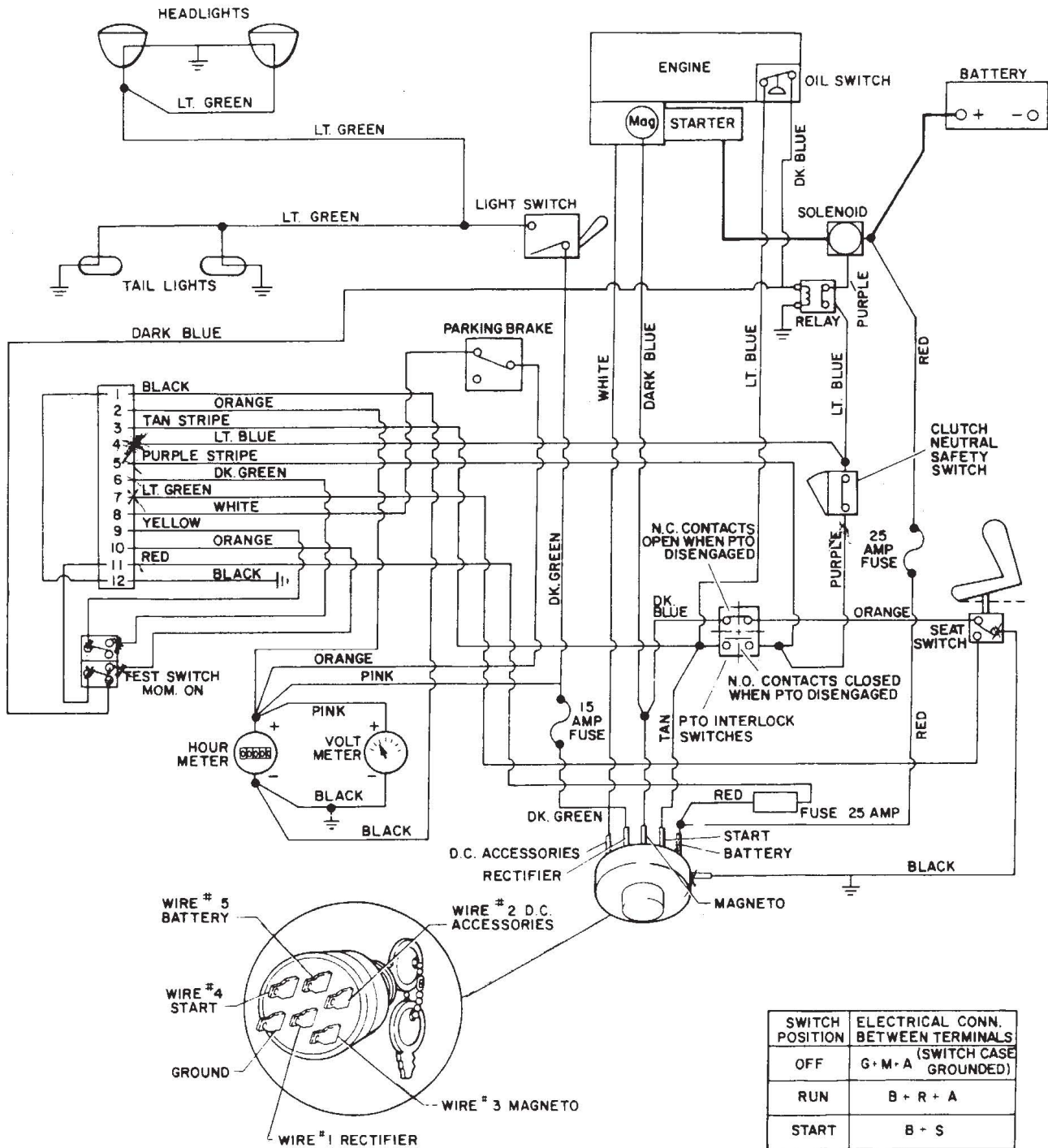

**Starter Motor Circuit**  
(ignition switch in "start")

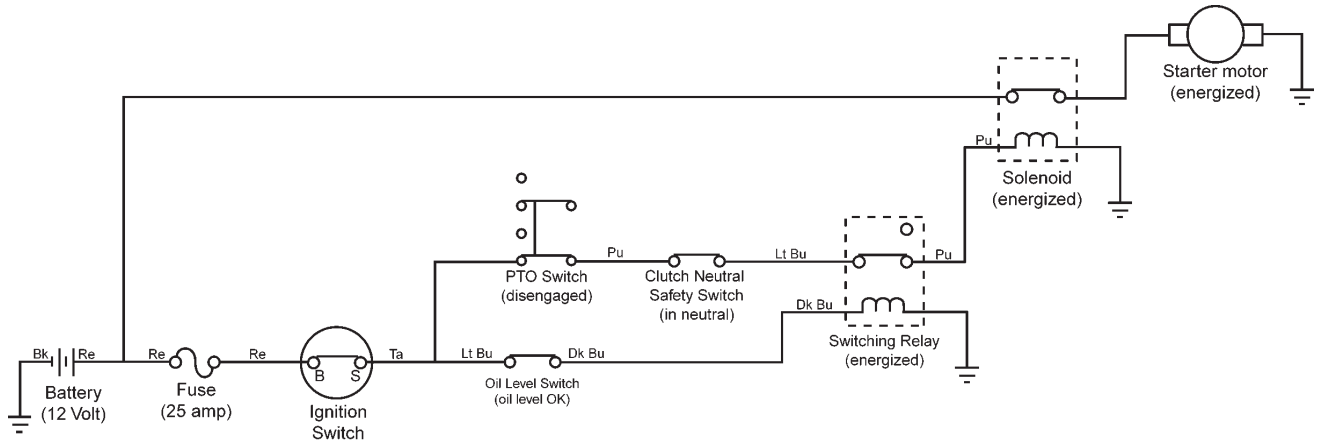

**Spark Circuit**  
(ignition switch in "start")

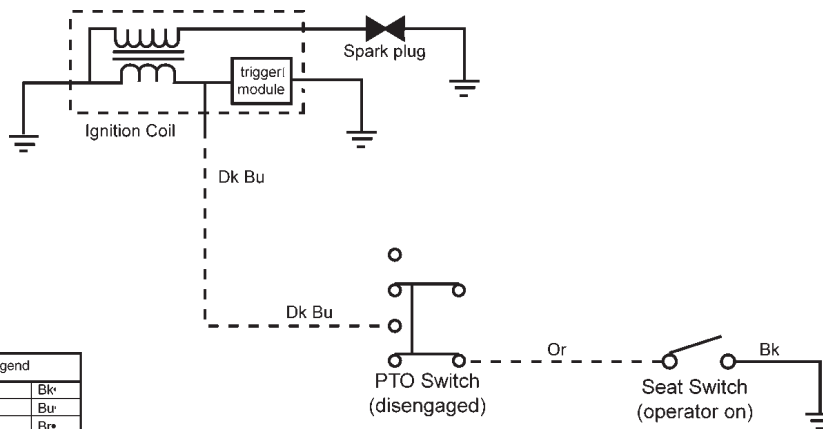

Legend	
Black*	Bk*
Blue*	Bu*
Brown*	Br*
Dark Blue*	Dk Bu*
Dark Green*	Dk Gr*
Green*	Gn*
Gray*	Gy*
Light Blue*	Lt Bu*
Orange*	Or*
Pink*	Pi*
Purple*	Pu*
Red*	Rd*
Tan*	Ta*
White*	Wh*
Yellow*	Ye*



**Charging Circuit**

(ignition switch in "run")

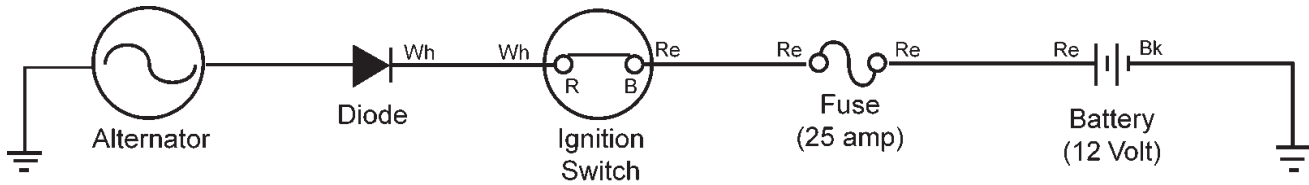

**Gauge Circuit**

(ignition switch in "run")

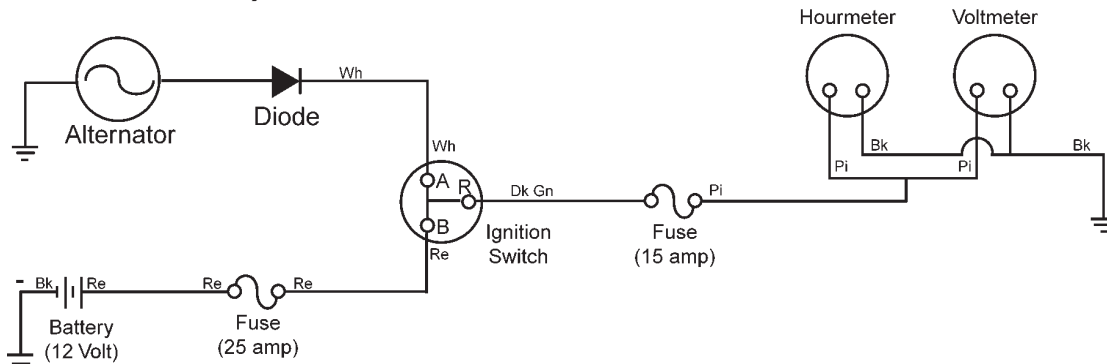

**Light Circuit**

(ignition switch in "run")

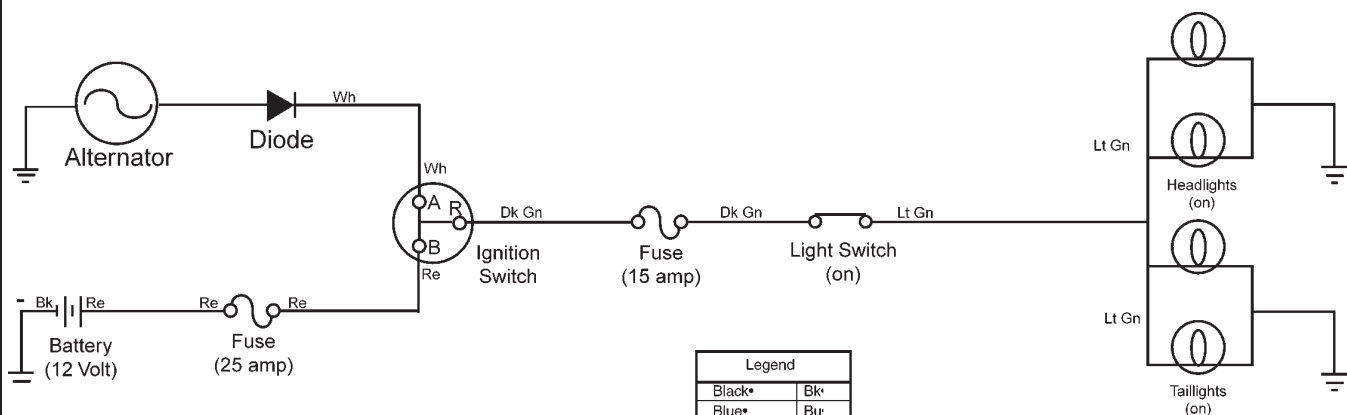

Legend	
Black*	Bk*
Blue*	Bu*
Brown*	Br*
Dark Blue*	Dk Bu*
Dark Green*	Dk Gn*
Green*	Gn*
Gray*	Gy*
Light Blue*	Lt Bu*
Orange*	Or*
Pink*	Pi*
Purple*	Pu*
Red*	Rd*
Tan*	Ta*
White*	Wh*
Yellow*	Ye*

Circuits

**Oil Circuit**  
*(with ignition switch in "start")*  
*(prevents starting if oil is low)*

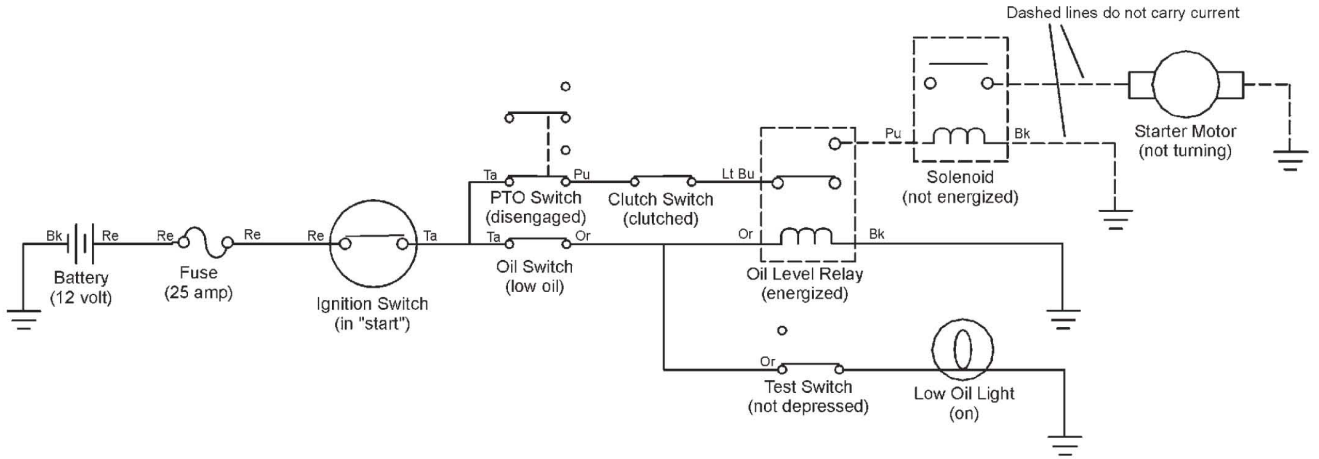

Legend	
Black*	Bk*
Blue*	Bu*
Brown*	Br*
Dark Blue*	Dk Bu*
Dark Green*	Dk Gn*
Green*	Gn*
Gray*	Gy*
Light Blue*	Lt Bu*
Orange*	Or*
Pink*	Pi*
Purple*	Pu*
Red*	Rd*
Tan*	Ta*
White*	Wh*
Yellow*	Ye*

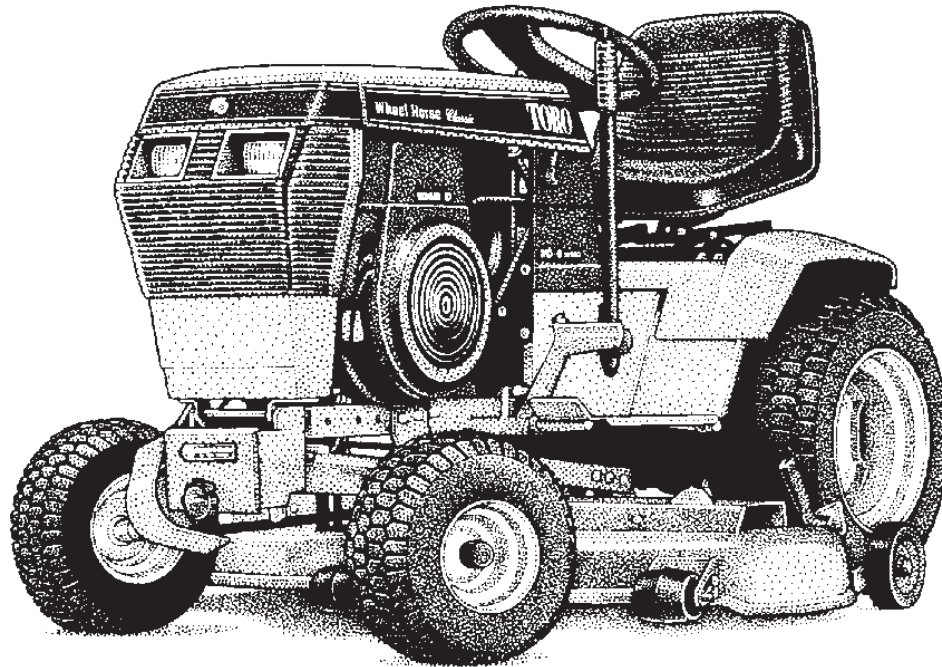

**312-8 Information List (1989)**

Wiring Diagram . . . . . 7-28

Circuit Diagrams

    Starter Motor Circuit . . . . . 7-29

    Spark Circuit . . . . . 7-29

    Gauge Circuit . . . . . 7-30

    Charging Circuit . . . . . 7-30

    Light Circuit . . . . . 7-30

    Oil Circuit . . . . . 7-31

Wiring Diagram

Wiring Diagram

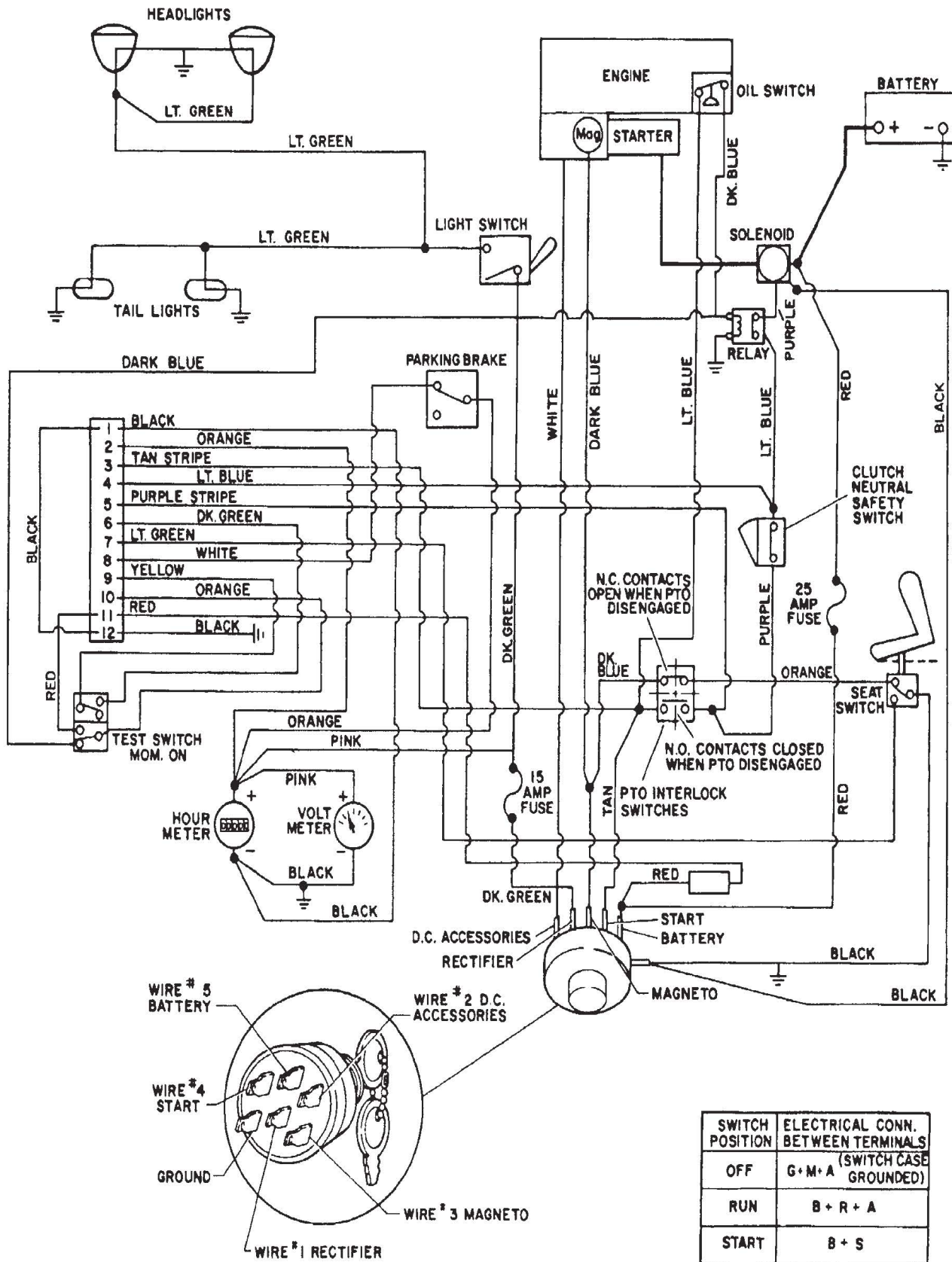

**Starter Motor Circuit**  
(ignition switch in "start")

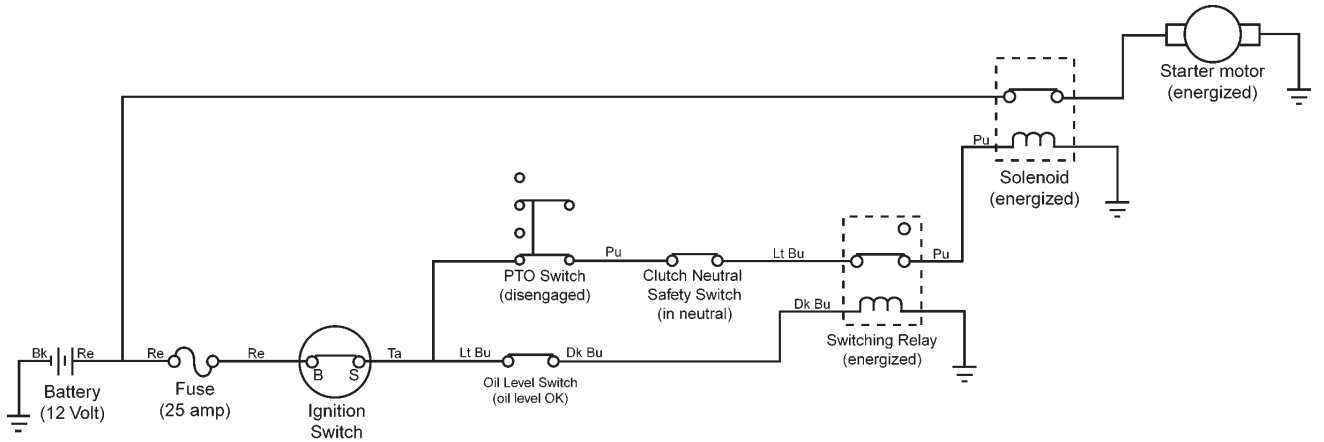

**Spark Circuit**  
(ignition switch in "start")

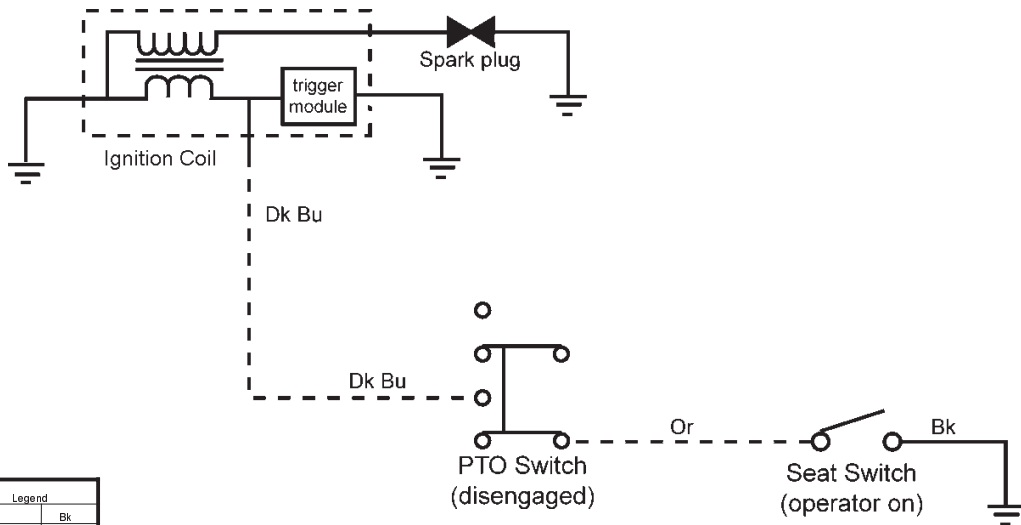

Legend	
Black	Bk
Blue	Bu
Brown	Br
Dark Blue	Dk Bu
Dark Green	Dk Gn
Green	Gn
Gray	Gy
Light Blue	Lt Bu
Orange	Or
Pink	Pi
Purple	Pu
Red	Rd
Tan	Ta
White	Wh
Yellow	Ye

**Gauge Circuit**

*(ignition switch in "run")*

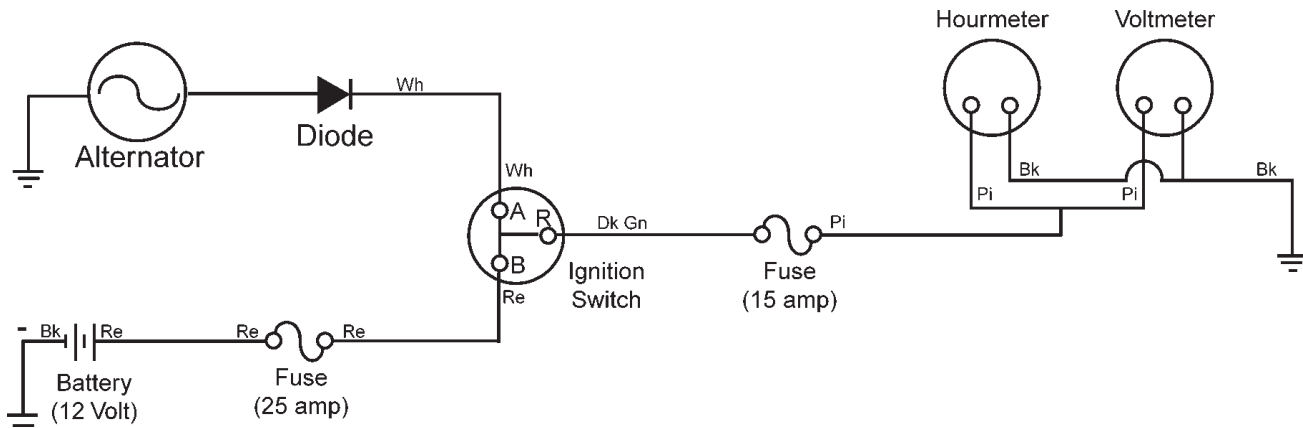

**Charging Circuit**

*(ignition switch in "run")*

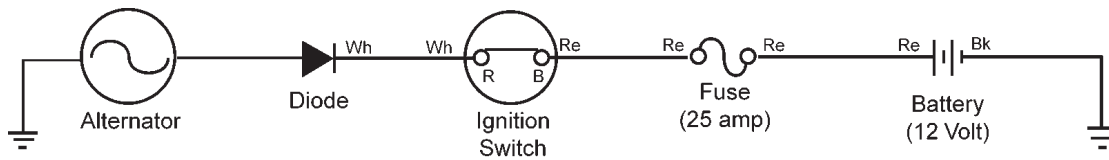

Legend	
Black	Bk
Blue	Bu
Brown	Br
Dark Blue	Dk Bu
Dark Green	Dk Gn
Green	Gn
Gray	Gy
Light Blue	Lt Bu
Orange	Or
Pink	Pi
Purple	Pu
Red	Rd
Tan	Ta
White	Wh
Yellow	Ye

**Light Circuit**

*(ignition switch in "run")*

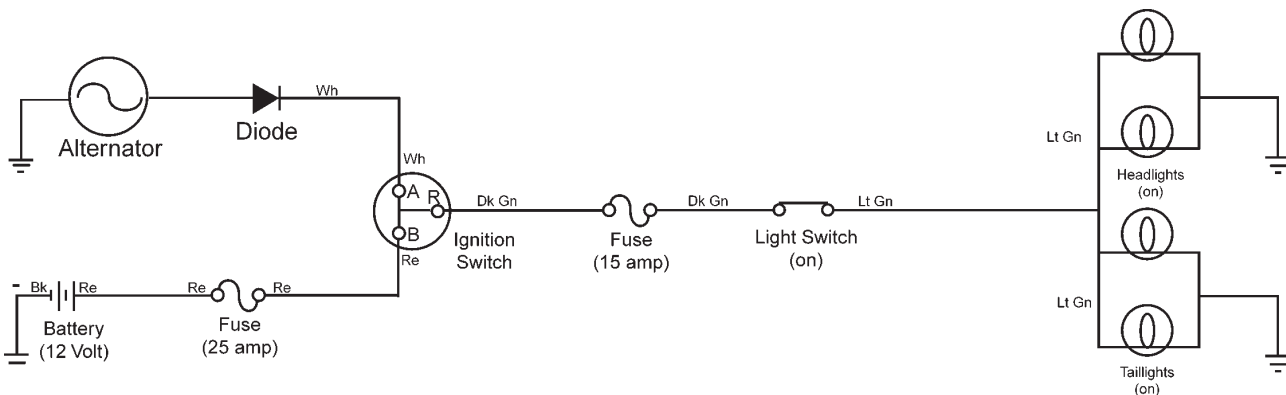

Circuits

**Oil Circuit**  
**(with ignition switch in "start")**  
**(prevents starting if oil is low)**

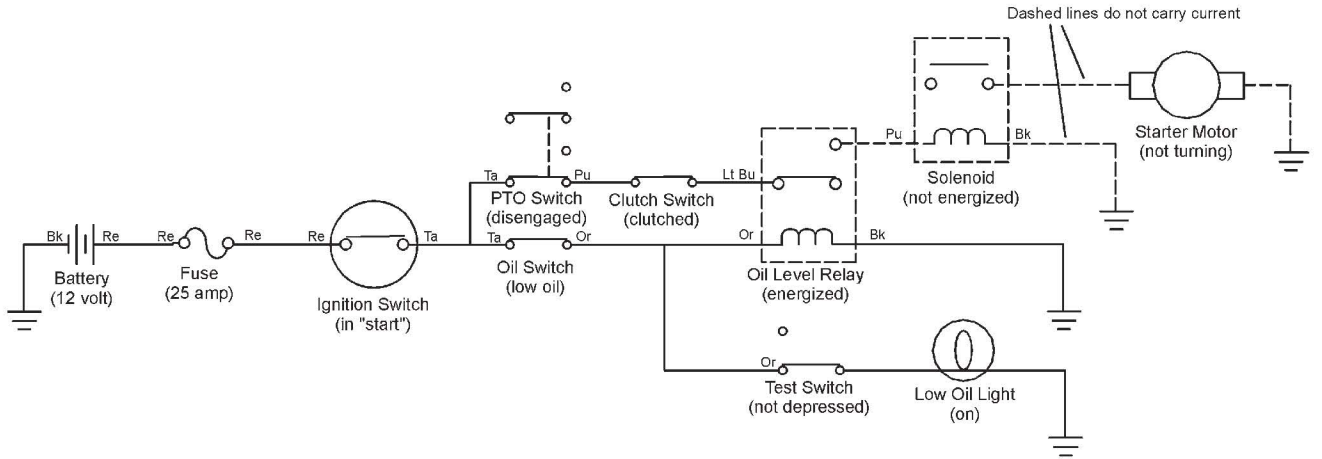

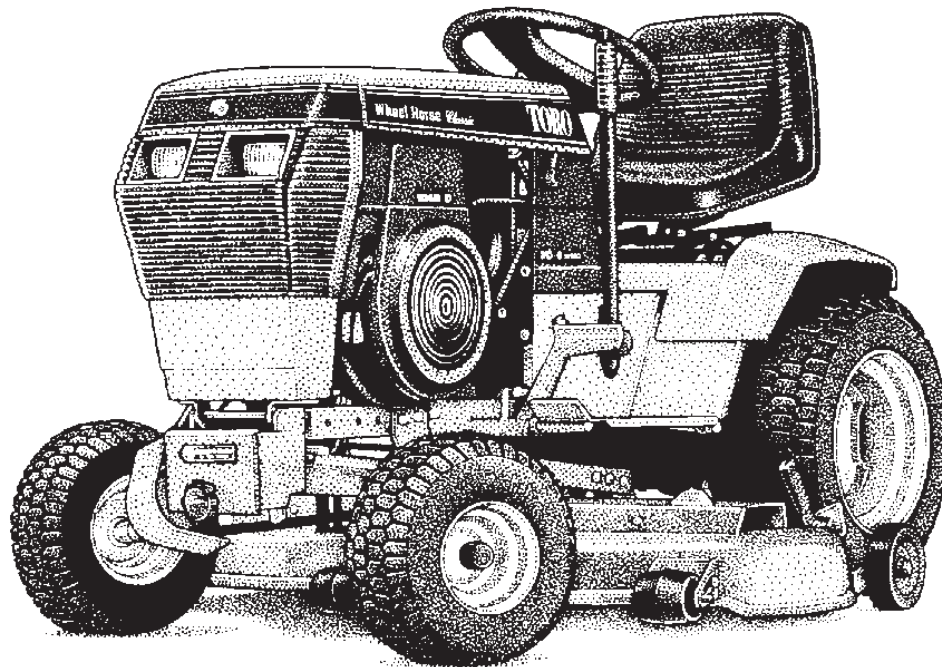

**312-H & 312-8 Information List (1990 - 1991)**

Wiring Diagram . . . . . 7-40

Circuit Diagrams

- Starter Motor Circuits . . . . . 7-41
- Spark Circuit . . . . . 7-42
- Charging Circuit . . . . . 7-42
- Gauge Circuit . . . . . 7-42
- Light Circuit . . . . . 7-43



Wiring Diagram

Wiring Diagram

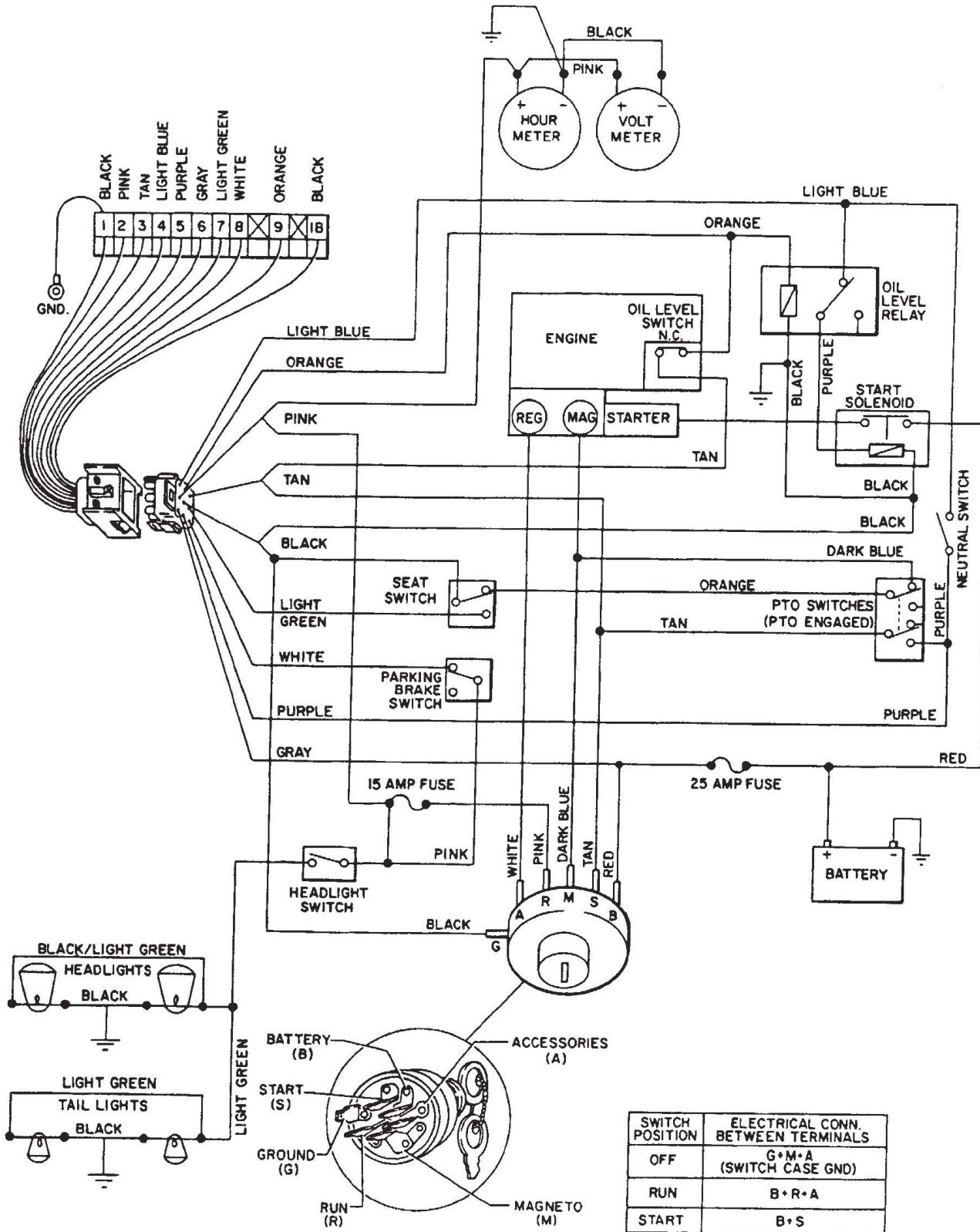

rev. 4-03

**Starter Motor Circuit**  
(Ignition switch in "start")

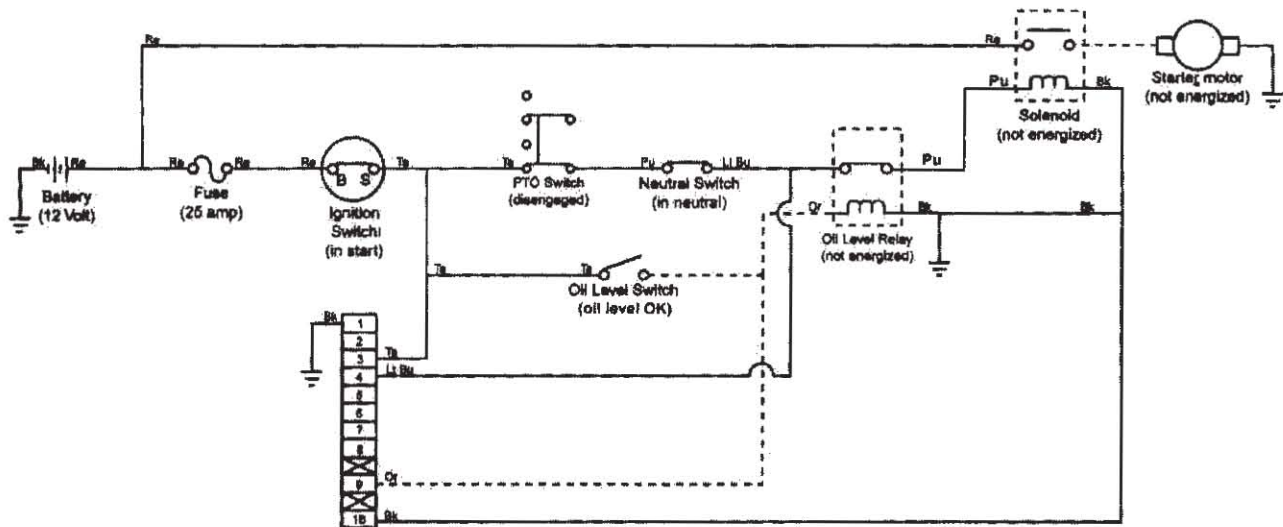

**Starter Motor Circuit**  
(Ignition switch in "start" with low oil level)

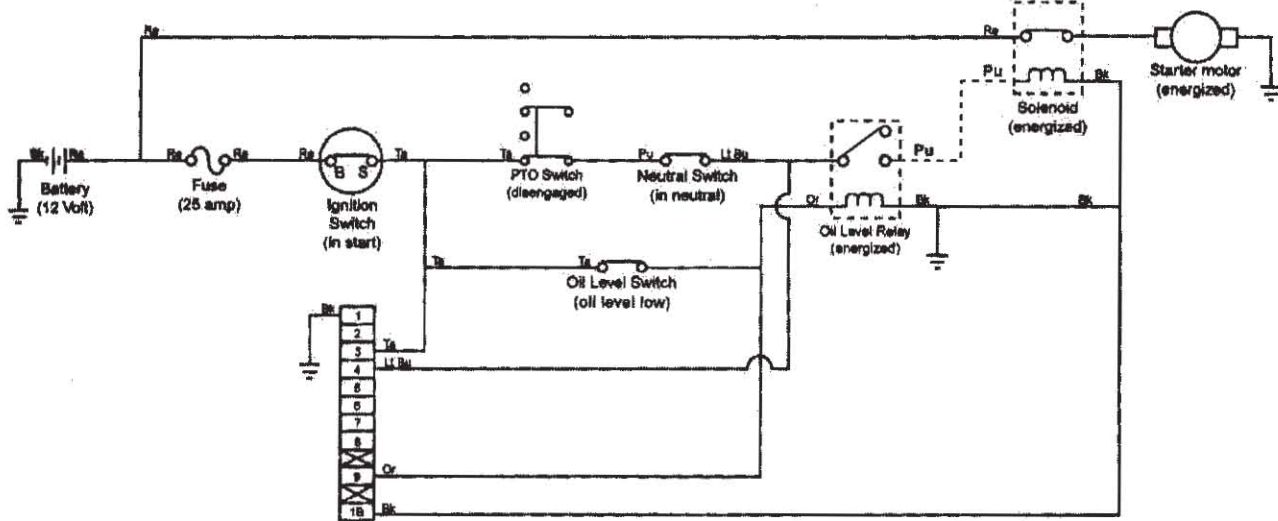

Legend	
Black	Bk
Blue	Bu
Brown	Br
Dark Blue	Dk Blu
Dark Green	Dk Grn
Green	Gr
Gray	Gy
Light Blue	Lt Blu
Orange	Or
Pink	Pk
Purple	Pu
Red	Rd
Tan	Tn
White	Wh
Yellow	Ye

Circuits

**Spark Circuit**

(ignition switch in "start")

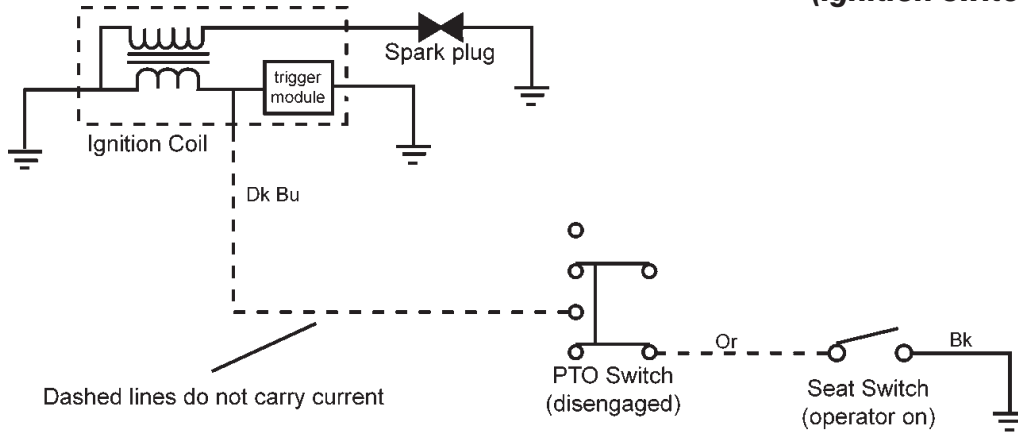

**Charging Circuit**

(ignition switch in "run")

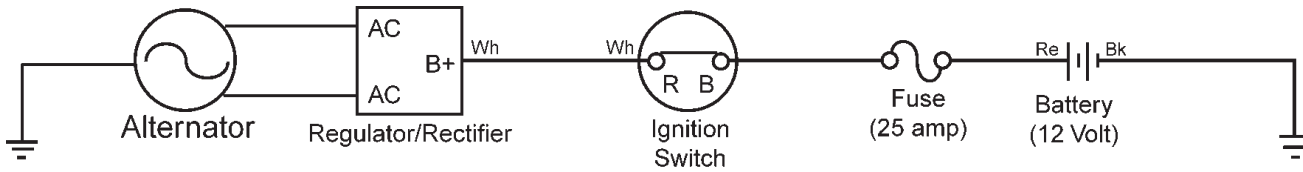

**Gauge Circuit**

(ignition switch in "run")

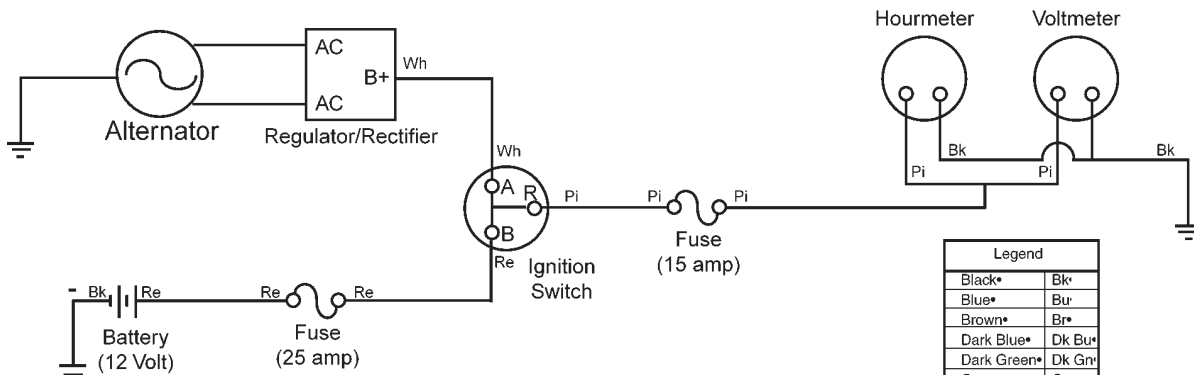

Legend	
Black*	Bk*
Blue*	Bu*
Brown*	Br*
Dark Blue*	Dk Bu*
Dark Green*	Dk Gr*
Green*	Gn*
Gray*	Gy*
Light Blue*	Lt Bu*
Orange*	Or*
Pink*	Pi*
Purple*	Pu*
Red*	Rd*
Tan*	Ta*
White*	Wh*
Yellow*	Ye*

**Light Circuit**  
(ignition switch in "run")

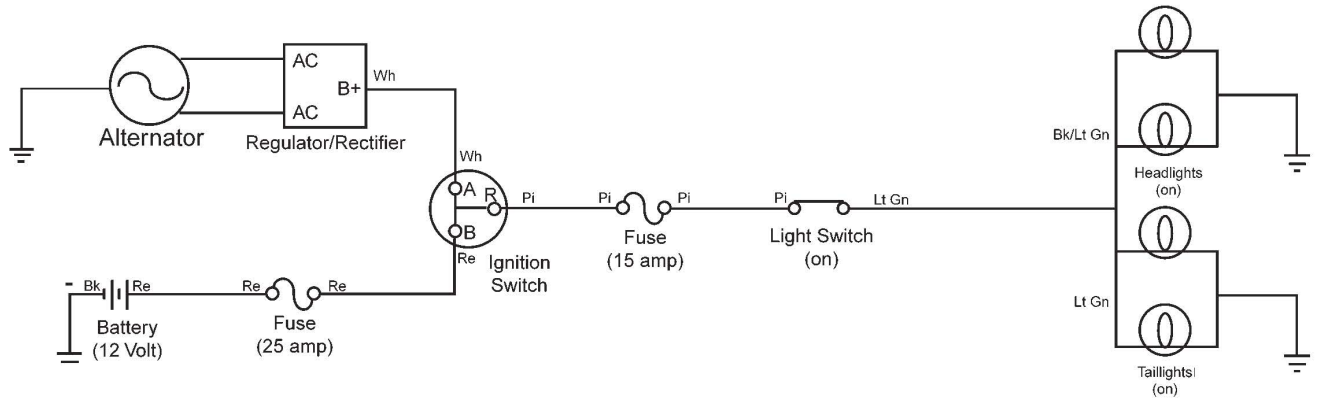

Legend	
Black*	Bk*
Blue*	Bu*
Brown*	Br*
Dark Blue*	Dk Bu*
Dark Green*	Dk Gn*
Green*	Gn*
Gray*	Gy*
Light Blue*	Lt Bu*
Orange*	Or*
Pink*	Pi*
Purple*	Pu*
Red*	Rd*
Tan*	Ta*
White*	Wh*
Yellow*	Ye*

310-8 - - - - - 1992-1993  
312-8 - - - - - 1992-1997

314-8 - - - - - 1993

rev. 4-03

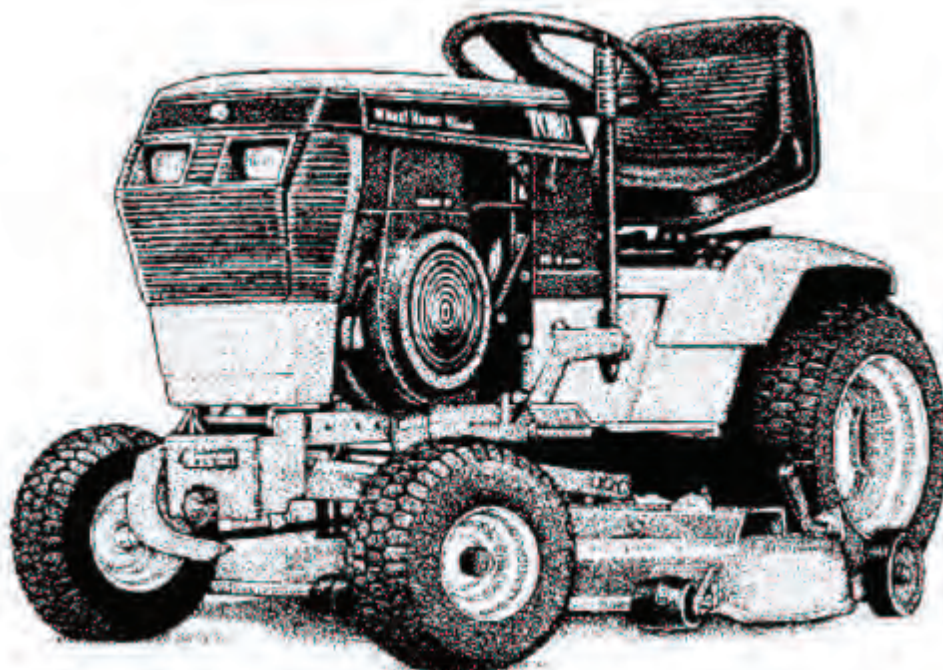

**Information List**

310-8 Information List (1992 - 1993)	
312-8 (1992 - 1997)	
314-8 (1993)	
Wiring Diagram . . . . .	7-24
Circuit Diagrams	
Starter Motor Circuit . . . . .	7-25
Spark Circuit . . . . .	7-25
Charging Circuit . . . . .	7-26
Light Circuit . . . . .	7-26
Hourmeter Circuit . . . . .	7-26

310-8 - - - - - 1992-1993  
 312-8 - - - - - 1992-1997

314-8 - - - - - 1993

Wiring Diagram

rev. 4-03

Wiring Diagram

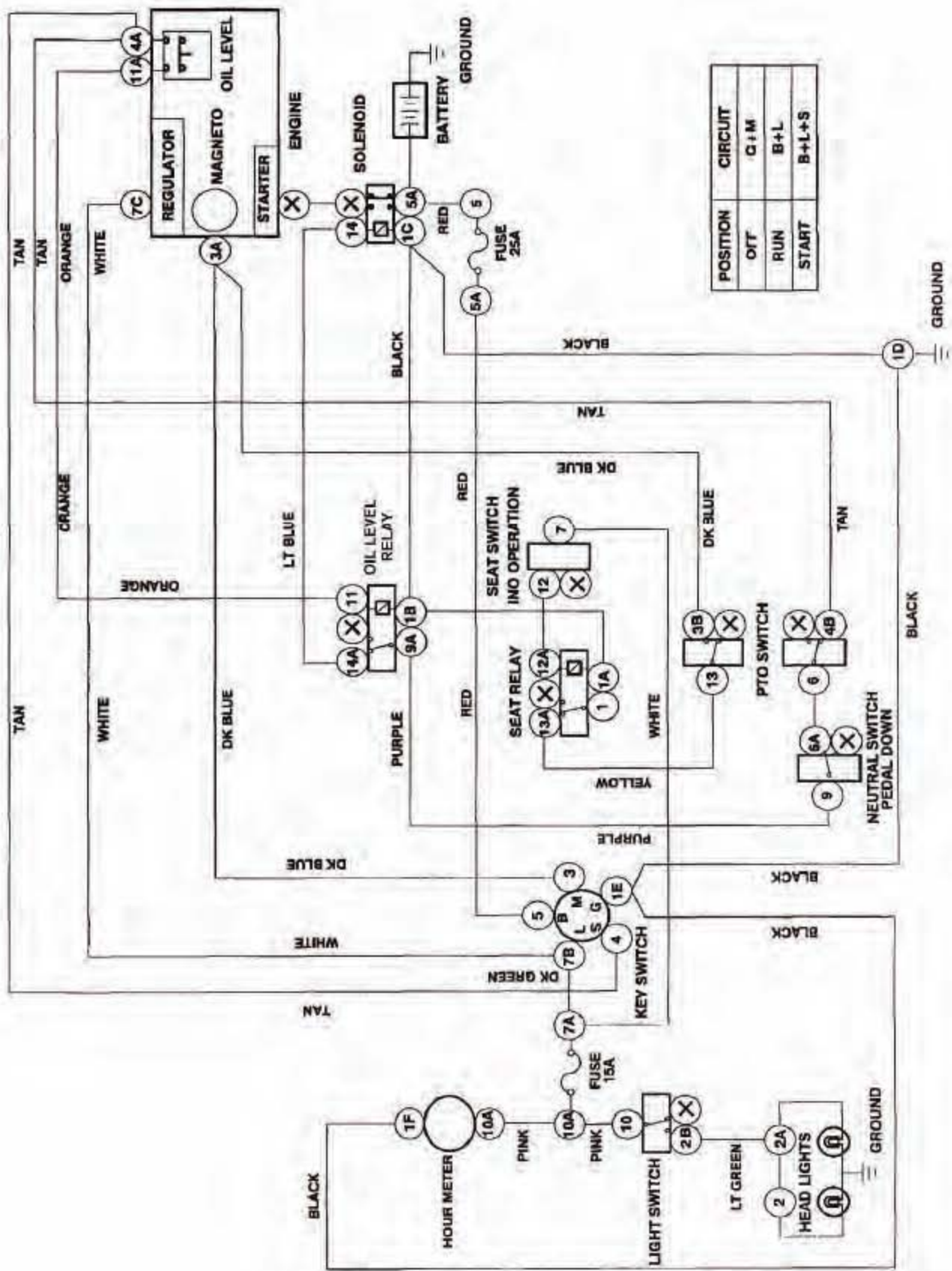

rev. 4-03

### Starter Motor Circuit (ignition switch in "start" with low oil level)

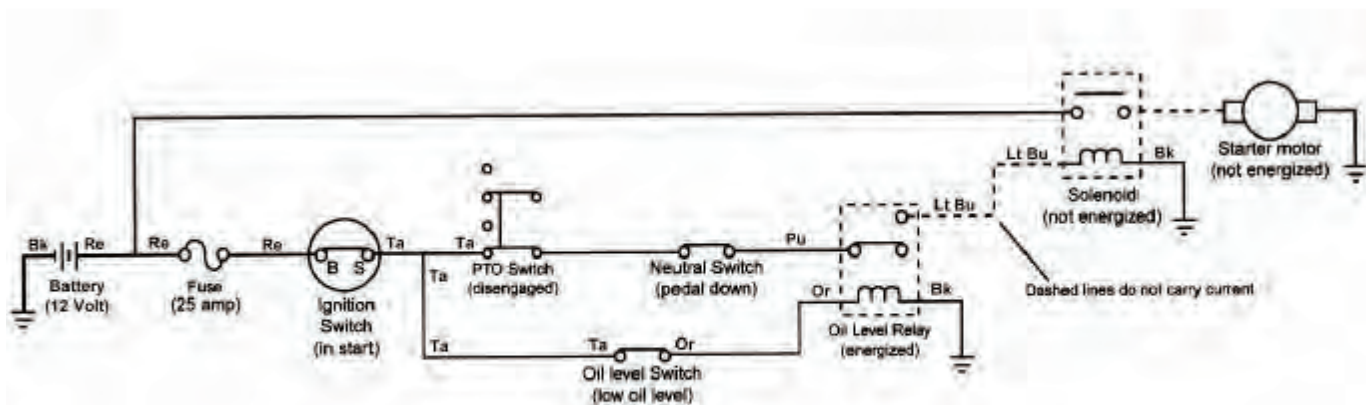

### Spark Circuit (ignition switch in "start")

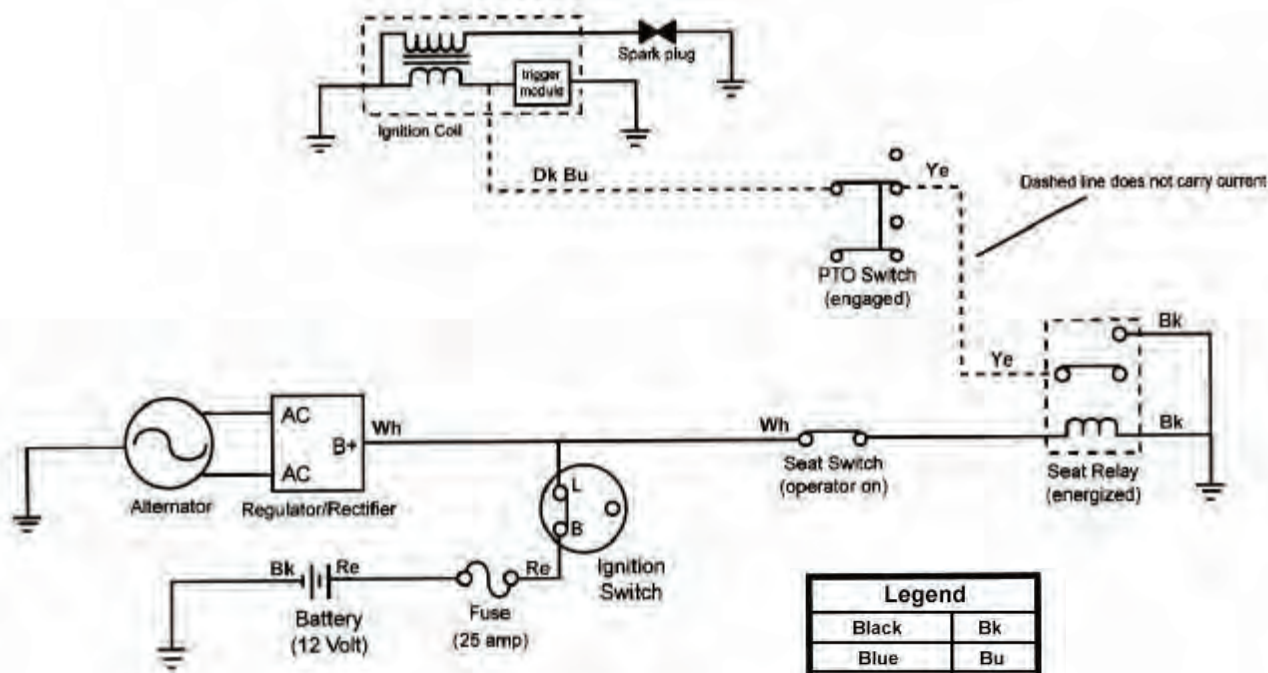

Legend	
Black	Bk
Blue	Bu
Brown	Br
Dark Blue	Dk Bu
Dark Green	Dk Gn
Green	Gn
Gray	Gy
Light Blue	Lt Bl
Orange	Or
Pink	Pi
Purple	Pu
Red	Re
Tan	Ta
White	Wh
Yellow	Ye

**Circuits**

Charging Circuit  
 (ignition switch in "run")

rev. 4-03

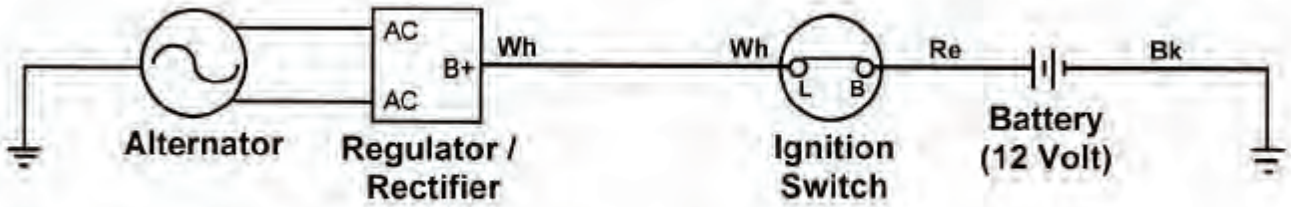

Light Circuit  
 (ignition switch in "run")

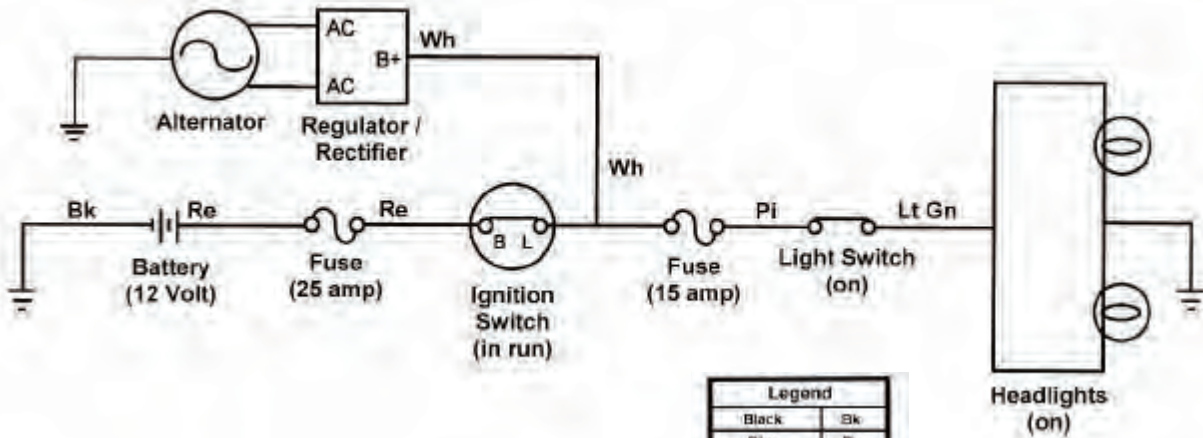

Legend	
Black	Bk
Blue	Bu
Brown	Br
Dark Blue	Dk Bu
Dark Green	Dk Gn
Green	Gn
Gray	Gy
Light Blue	Lt Bl
Orange	Or
Pink	Pi
Purple	Pu
Red	Re
Tan	Ta
White	Wh
Yellow	Ye

Hourmeter Circuit  
 (ignition switch in "run")

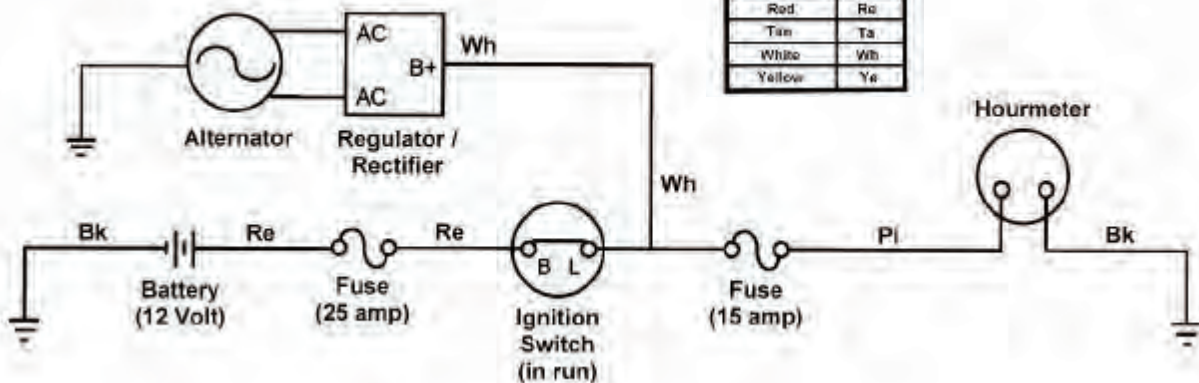

Circuits



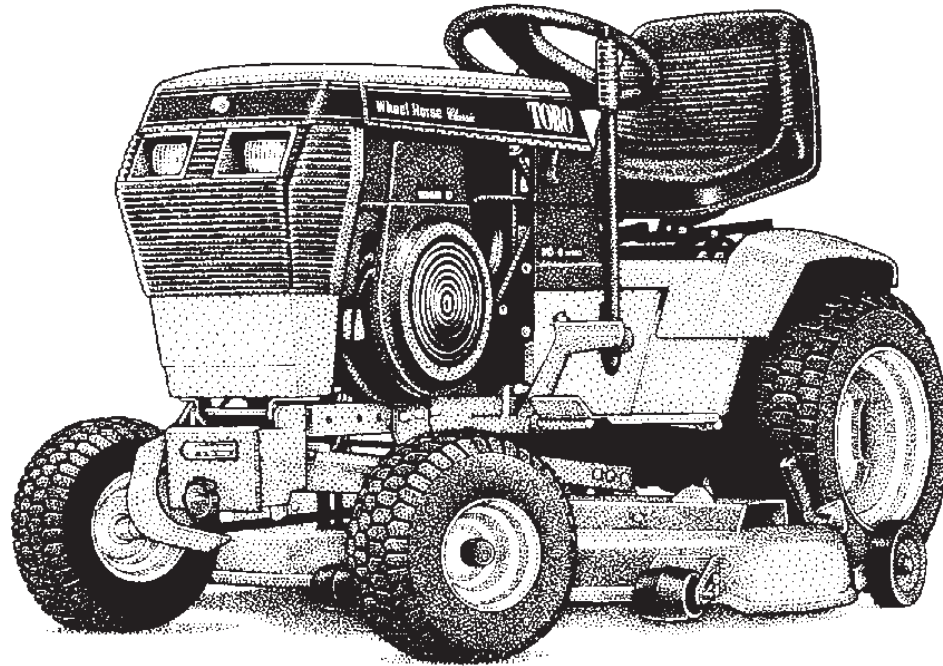

**312-8 Information List (1998)**

Wiring Diagram . . . . . 7-18

Circuit Diagrams

    Starter Motor Circuit . . . . . 7-19

    Spark Circuits . . . . . 7-19 & 7-20

    Charging Circuit . . . . . 7-20

    Hourmeter Circuit . . . . . 7-20

    Light Circuit . . . . . 7-21

# Wiring Diagram

312-8

Wiring Diagram

1998

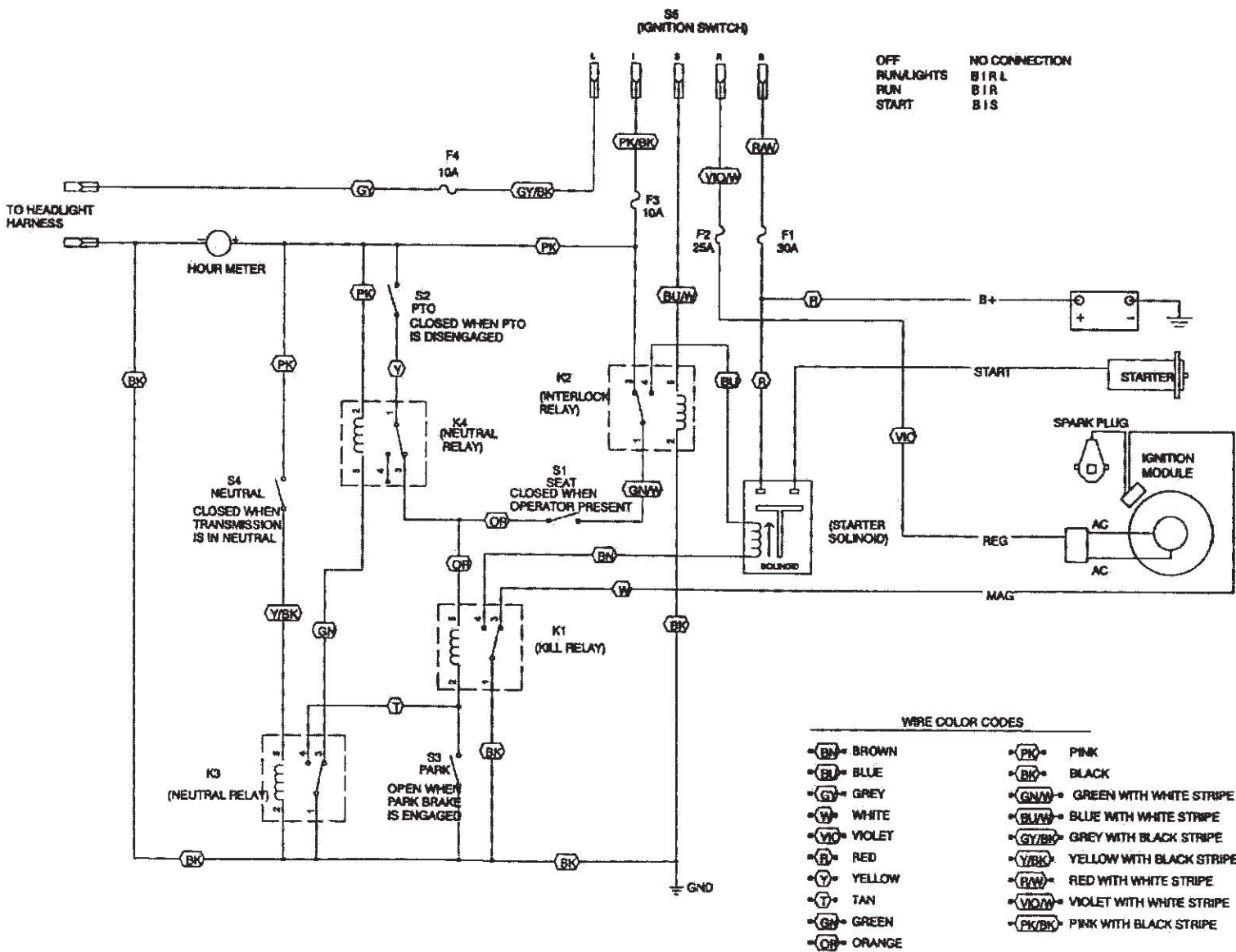

REV 4-03

### Starter Motor Circuit (ignition switch in "start")

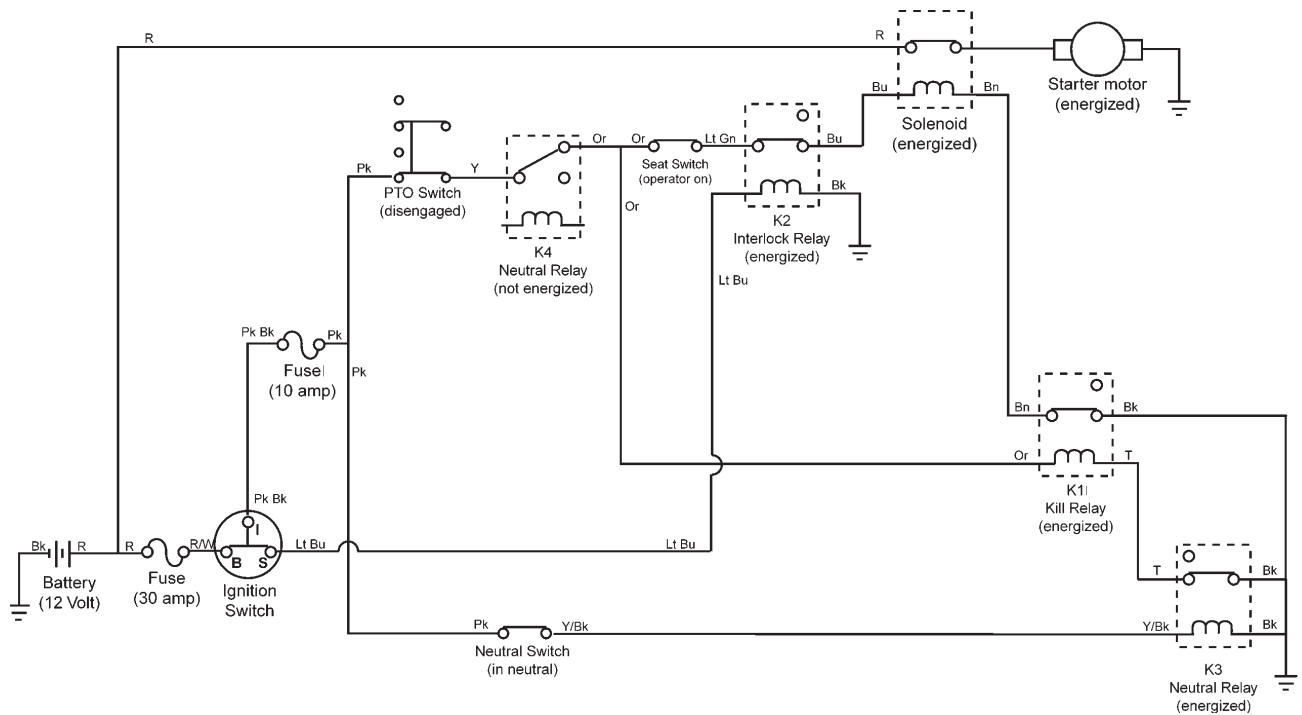

### Spark Circuit (ignition switch in "start")

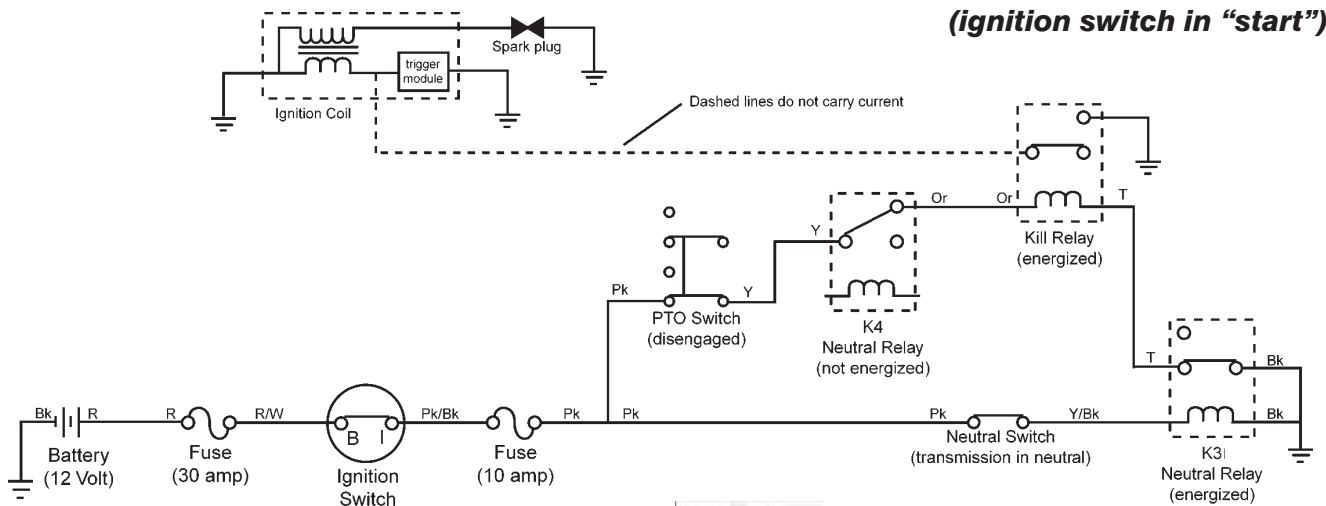

Legend	
Black	BK
Brown	BN
Blue	BU
Green	GN
Gray	GY
Orange	OR
Pink	P
Red	R
Tan	T
Violet	VIO
White	W
Yellow	Y

**Spark Circuit**

(ignition switch in "run")

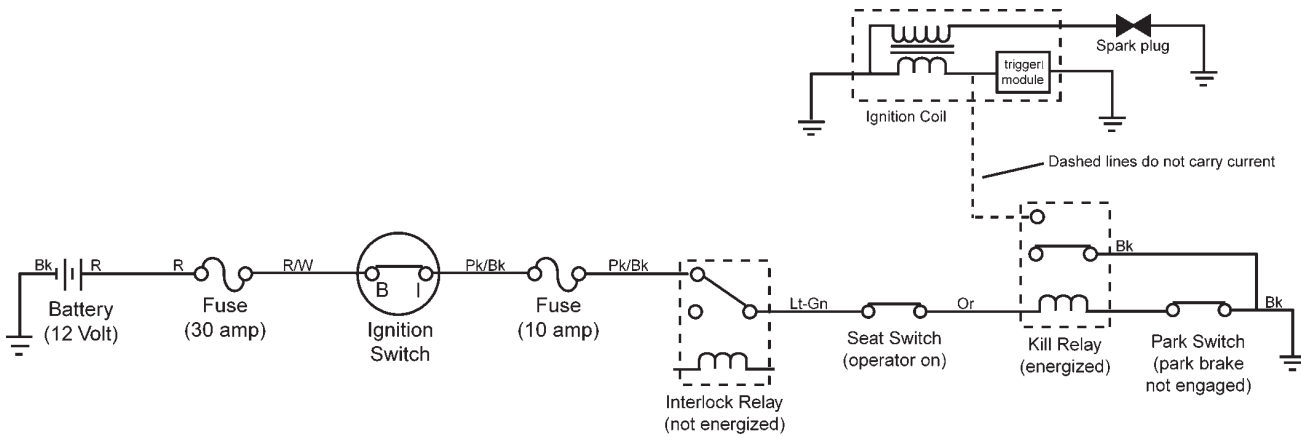

**Charging Circuit**

(ignition switch in "run")

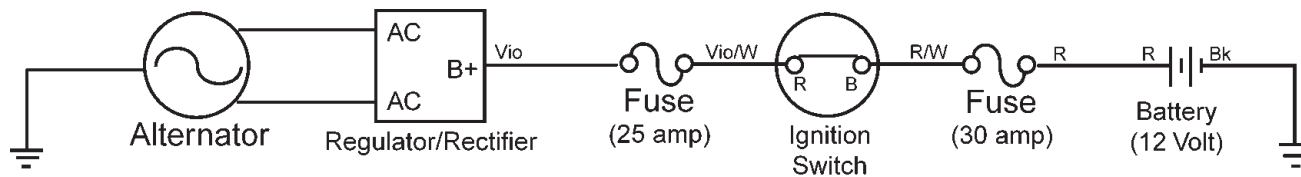

**Hourmeter Circuit**

(ignition switch in "run")

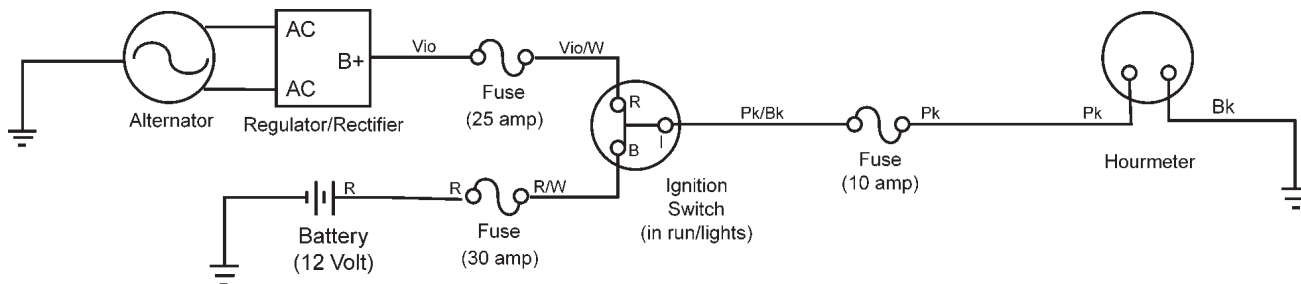

Legend	
Black	BK
Brown	BN
Blue	BU
Green	GN
Gray	GY
Orange	OR
Pink	P
Red	R
Tan	T
Violet	VIO
White	W
Yellow	Y

Circuits

**Light Circuit**  
(ignition switch in "run")

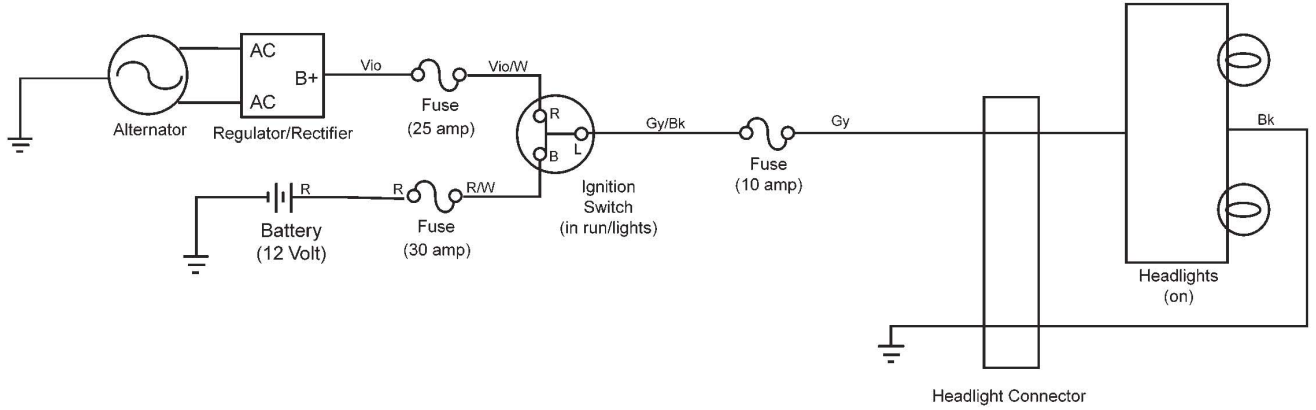

Legend	
Black	BK
Brown	BN
Blue	BU
Green	GN
Gray	GY
Orange	OR
Pink	P
Red	R
Tan	T
Violet	VIO
White	W
Yellow	Y

rev. 4-03

**Starter Motor Circuit**  
(ignition switch in "start")

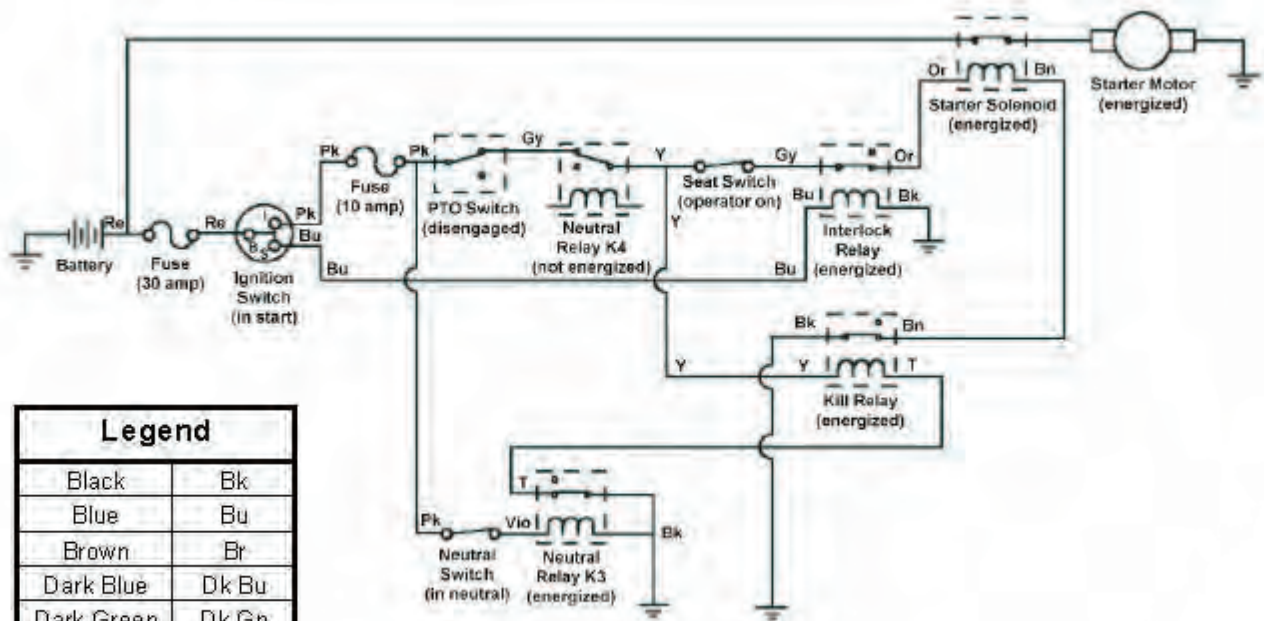

Legend	
Black	Bk
Blue	Bu
Brown	Br
Dark Blue	Dk Bu
Dark Green	Dk Gn
Green	Gn
Gray	Gy
Light Blue	Lt Bu
Orange	Or
Pink	Pi
Purple	Pu
Red	Re
Tan	Ta
White	Wh
Yellow	Ye

**Spark Circuit**  
(ignition switch in "start")

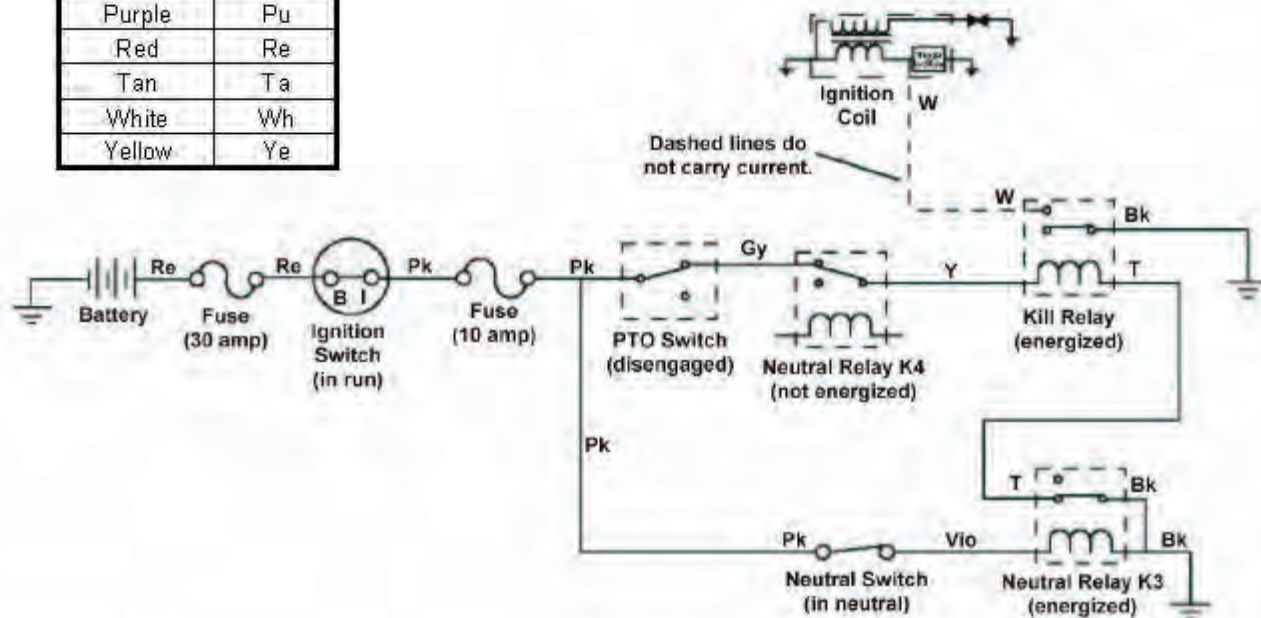

**Circuits**

Run Forward  
(PTO "on")

rev. 4-03

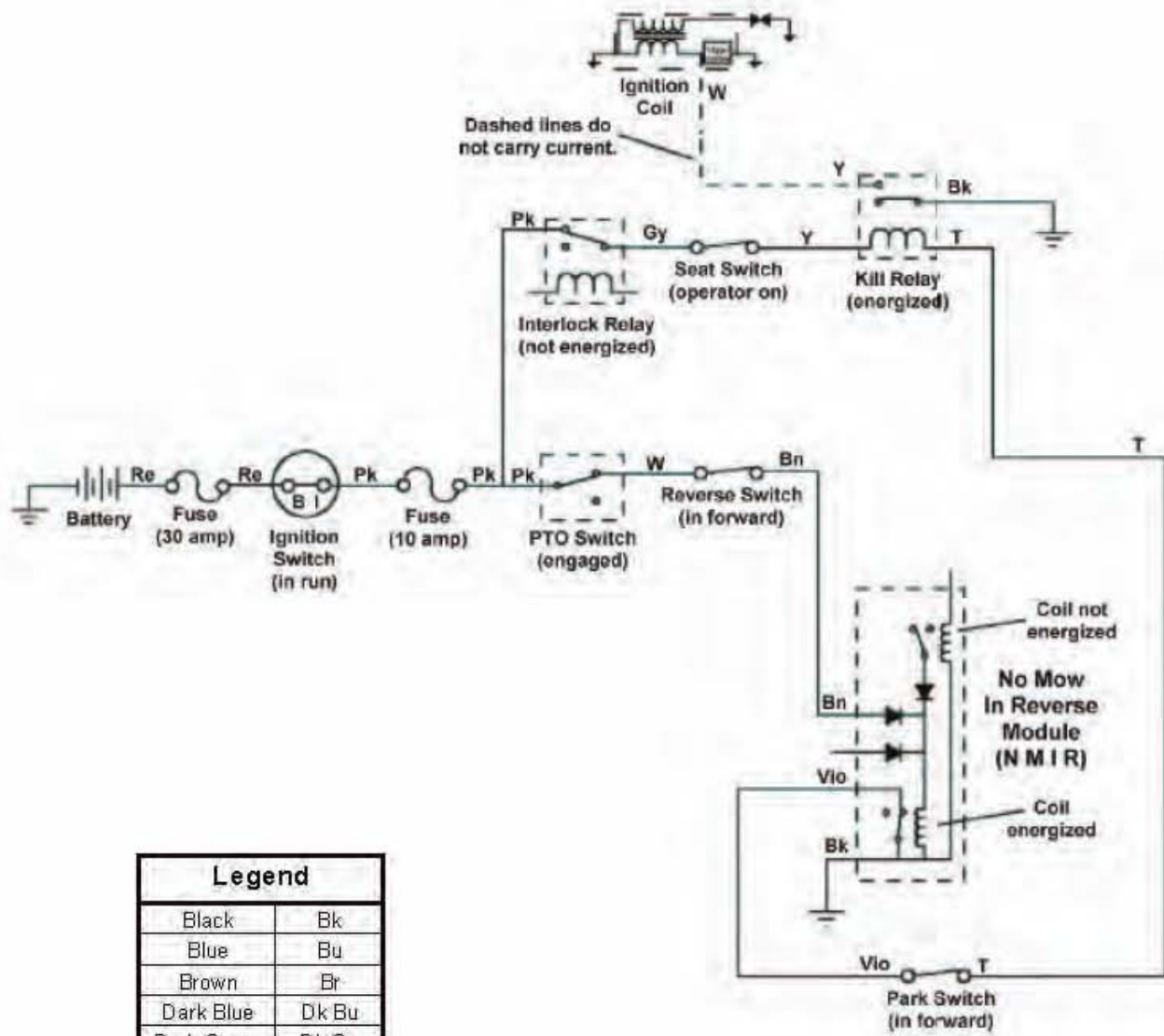

Legend

Black	Bk
Blue	Bu
Brown	Br
Dark Blue	Dk Bu
Dark Green	Dk Gn
Green	Gn
Gray	Gy
Light Blue	Lt Bu
Orange	Or
Pink	Pi
Purple	Pu
Red	Re
Tan	Ta
White	Wh
Yellow	Ye

rev. 4-03

Run Reverse  
(PTO "on" NMIR override)

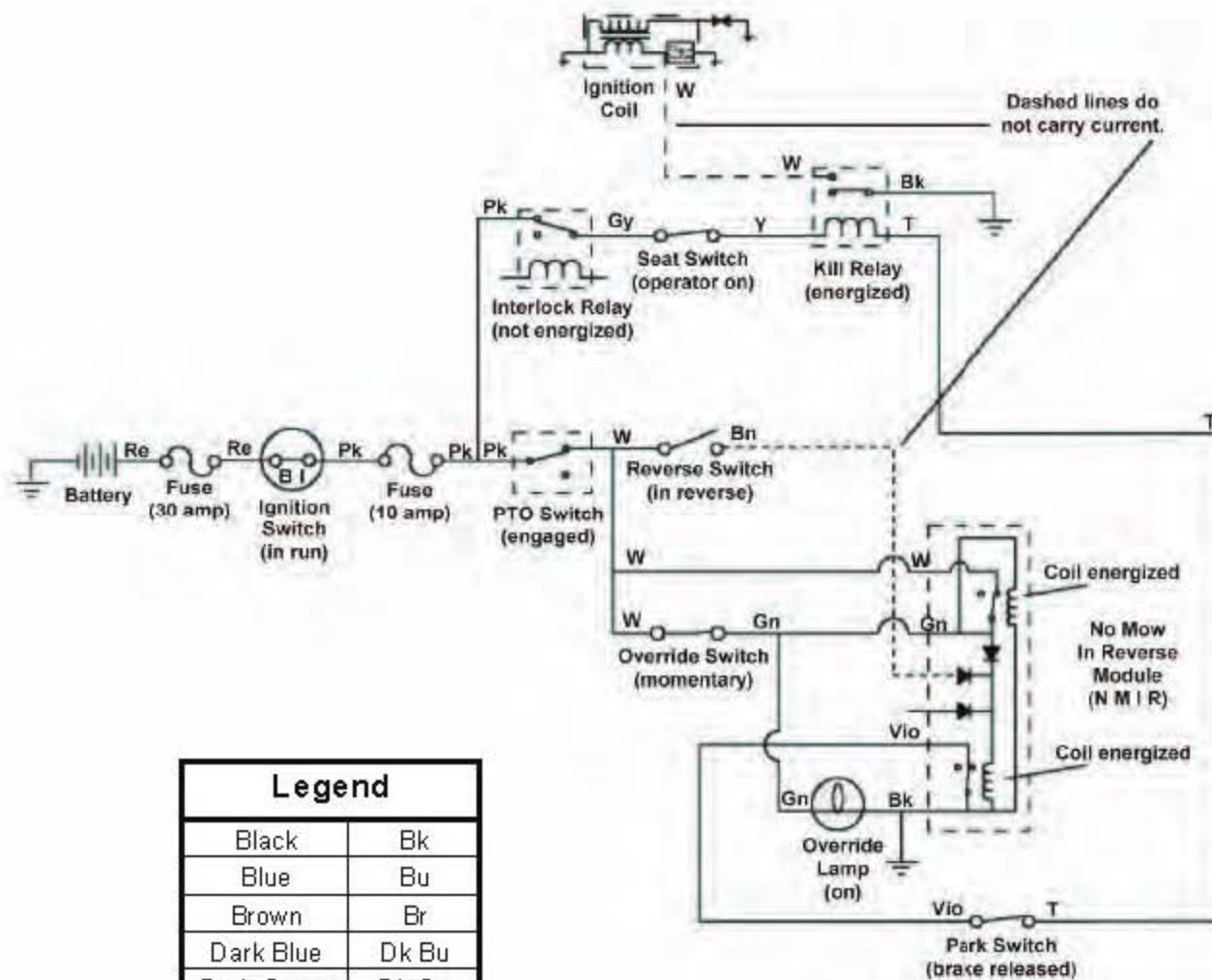

Legend	
Black	Bk
Blue	Bu
Brown	Br
Dark Blue	Dk Bu
Dark Green	Dk Gn
Green	Gn
Gray	Gy
Light Blue	Lt Bu
Orange	Or
Pink	Pi
Purple	Pu
Red	Re
Tan	Ta
White	Wh
Yellow	Ye

**Circuits**



Charging Circuit

rev. 4-03

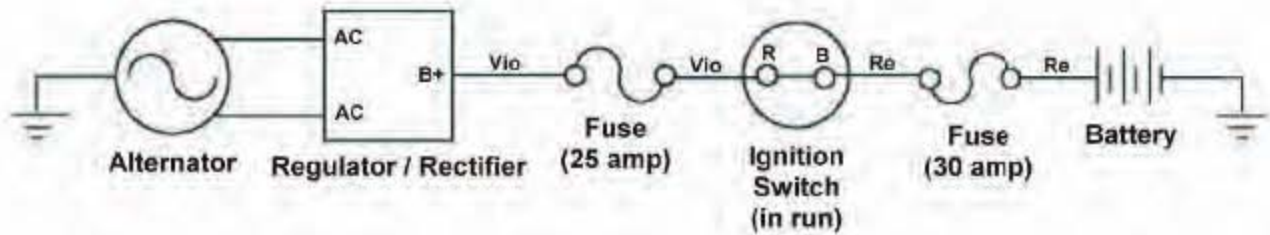

Light Circuit

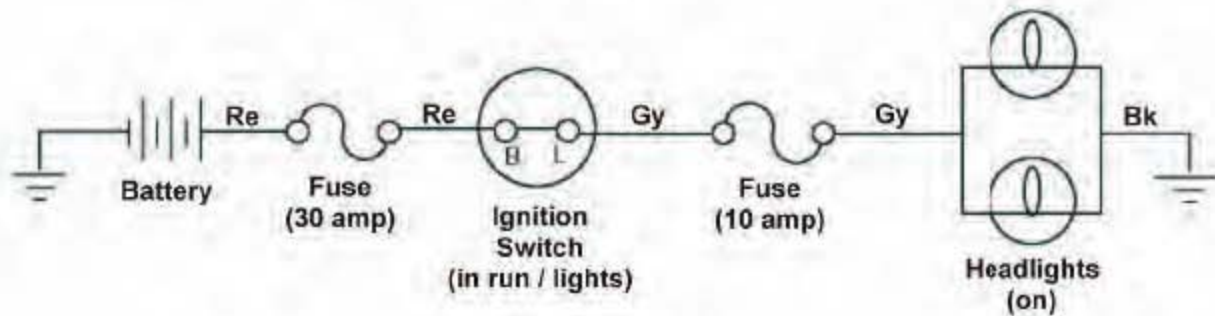

Legend	
Black	Bk
Blue	Bu
Brown	Br
Dark Blue	Dk Bu
Dark Green	Dk Gn
Green	Gn
Gray	Gy
Light Blue	Lt Bu
Orange	Or
Pink	Pi
Purple	Pu
Red	Re
Tan	Ta
White	Wh
Yellow	Ye