

3600CB
347-2400R

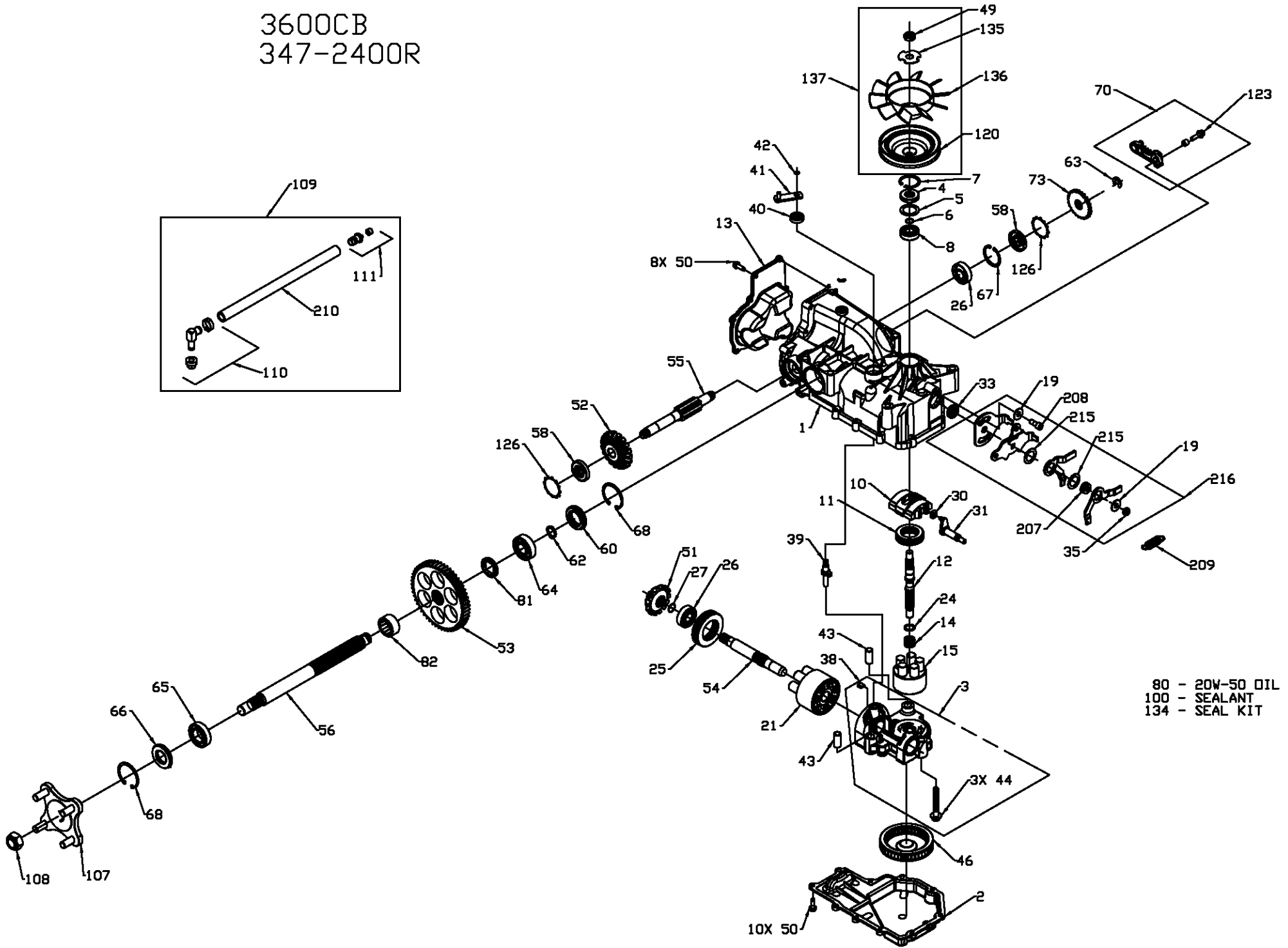

80 - 20W-50 OIL
100 - SEALANT
134 - SEAL KIT

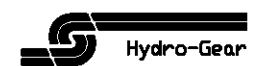

3600CB
347-2400R

ITEM NO.	HYDRO-GEAR PART NO.	QTY.	DESCRIPTION
1	70627	1	KIT, HOUSING-MAIN
		1	HOUSING, MAIN
		2	CRADLE BEARING
		1	LIP SEAL
		1	TRUNNION BUSHING
2	50890RM	1	LOWER HOUSING
3	70679	1	KIT, CENTER SECTION
		1	CENTER SECTION
		1	BUSHING .67 X 1.03 X .75
		1	PLATE, BYPASS
		1	SCREW, 3/8-24 X 2.5
		2	CHECK PLUG ASSEMBLY, .044
4	9008000-0128	1	LIP SEAL
5	2003018	1	SPACER
6	2003016	1	WIRE RETAINING RING
7	2003052	1	RETAINING RING
8	2003043	1	BALL BEARING
10	2003087	1	VARIABLE SWASHPLATE
11	50551	1	THRUST BEARING 30 X 52 X 13
12	50005	1	INPUT SHAFT
13	50891RM	1	COVER-BACK
14	2003014	1	SPRING, BLOCK
15	70331	1	10cc CYLINDER BLOCK ASS'Y
		1	10cc CYLINDER BLOCK
		5	10cc PISTON SPRING
		5	PISTON SEAT WASHER
		5	10cc PISTON
19	44130	2	WASHER
21	70082	1	21cc CYLINDER BLOCK ASS'Y
		1	21cc CYLINDER BLOCK
		7	21cc PISTON SPRING
		7	PISTON SEAT WASHER
		7	21cc PISTON
24	2003017	1	WASHER, BLOCK THRUST
25	50552	1	THRUST BEARING 42 X 68 X 16
26	50315	2	BALL BEARING
27	2000022	1	WIRE RETAINING RING
30	2000015	1	SLOT GUIDE
31	50807	1	TRUNNION ARM
33	9008000-0126	1	LIP SEAL
35	50108	1	HEX LOCK NUT, 5/16-24 UNJF (NYLON INSERT)
38	70680	1	KIT, BYPASS PLATE
39	2003555	1	BYPASS ACTUATOR
40	45074	1	LIP SEAL
41	50270	1	BYPASS ARM
42	44870	1	RETAINING RING
43	50002	2	PIN

ITEM NO.	HYDRO-GEAR PART NO.	QTY.	DESCRIPTION
44	50016	3	SCREW
46	50990	1	FILTER
49	51244	1	HEX LOCK NUT 1/2-20 (NYLON INSERT)
50	50752	1	SCREW, 1/4-20 X .75 LONG
51	50744	1	14T BEVEL GEAR
52	50745	1	19T BEVEL GEAR
53	50746	1	53T SPUR GEAR
54	50757	1	MOTOR SHAFT
55	51298	1	BRAKE SHAFT
56	50748	1	SHAFT, AXLE 1.0 X 12.3
58	51161	2	SEAL, LIP 17 X 40 X 7
60	50995	1	SEAL PLUG - SIDE
62	50759	1	RETAINING RING - AXLE
64	50743	1	BEARING-BALL 20X47X14(6204)
65	50740	1	BEARING-BALL 25X47X12(6005)
66	50751	1	SEAL
67	50329	1	RETAINING RING
68	50760	2	RETAINING RING-AXLE
70	70392	1	RH BRAKE ARM SERVICE ASSEMBLY
		1	BRAKE ARM
		1	CLEVIS PIN
		1	BUSHING .255 X .381 X .330
		1	HEX WASHER HEAD SCREW, 1/4-20 X 7/8
80		79oz	20W-50 OIL
81	50942-2	1	AXLE BUSHING
82	50942-1	1	AXLE BUSHING
100	50928	1	SEALANT
107	70314	1	HUB ASSEMBLY
		1	HUB
		1	BOLT, LUG
108	50863	1	NUT, HEX 3/4-16
109	70592	1	KIT, BREATHER
		1	BUSHING-VENT
		1	CAP-POPPET VALVE
		1	ST .5 BARB VENT
		1	90 .45 BARB .5 BEAD
		1	CLAMP-PINCH 13/16
		1	HOSE .5X12
		1	KIT, CAP-VENT
		1	KIT, HOSE-FITTING
110	70588	1	KIT, HOSE-FITTING
		1	90 .45 BARB .5 BEAD
		1	CLAMP-PINCH 13/16
		1	HOSE .5X12
111	70109	1	KIT, CAP VENT
		1	CAP-POPPET VALVE
		1	ST .5 BARB VENT

ITEM NO.	HYDRO-GEAR PART NO.	QTY.	DESCRIPTION
120	51363	1	PULLEY, 4.5
123	51076	1	SCREW, HFHC 1/4-28 X 7/8 (PATCH)
126	51316	2	RING, RETAINING
134	70553	1	KIT, SEAL
		1	SEAL, LIP 15 X 35 X 7
		1	RING, RETAINING
		1	SEAL, LIP 12 X 25 X 7
		1	SEAL, LIP 10 X 25 X 7
		1	RING, RETAINING
		2	SEAL, LIP 17 X 40 X 7
		1	SEAL, LIP 1.85 X .32
		1	RING, RETAINING
		1	RING, RETAINING .440 EXTERNAL
		1	SEAL, LIP .98 X 1.85 X .276
		1	RING, RETAINING
		2	RING, RETAINING
		2	RING, RETAINING
		2	SEAL, LIP 17 X 40 X 5
135	51523	1	WASHER, OIL SLOTTED, .53 X 1.63 X .06
136	51364	1	FAN, 6", 10 BLADE
137	70600	1	KIT, FAN-PULLEY
		1	WASHER, OIL SLOTTED, .53 X 1.63 X .06
		1	FAN, 6", 10 BLADE
		1	HEX LOCK NUT 1/2-20 (NYLON INSERT)
		1	PULLEY, 4.5
207	51396	1	SPACER, RTN
208	51400	1	SCREW, 5/16-24 X .75 (PATCH)
209	51399	1	SPRING, EXTENSION
210	50632	1	HOSE 12"
215	51408	2	WASHER, NYLON
216	70609	1	RTN, KIT
		2	WASHER
		1	HEX LOCK NUT, 5/16-24 UNJF (NYLON INSERT)
		1	SPACER, RTN
		1	SCREW, 5/16-24 X .75 (PATCH)
		1	SPRING, EXTENSION
		2	WASHER, NYLON
		1	CONTROL ARM
		1	ARM, RTN SCISSOR, OUTER
		1	ARM, RTN SCISSOR, INNER
		1	ARM, RETURN

