

D38154
324-2400R

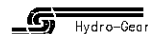
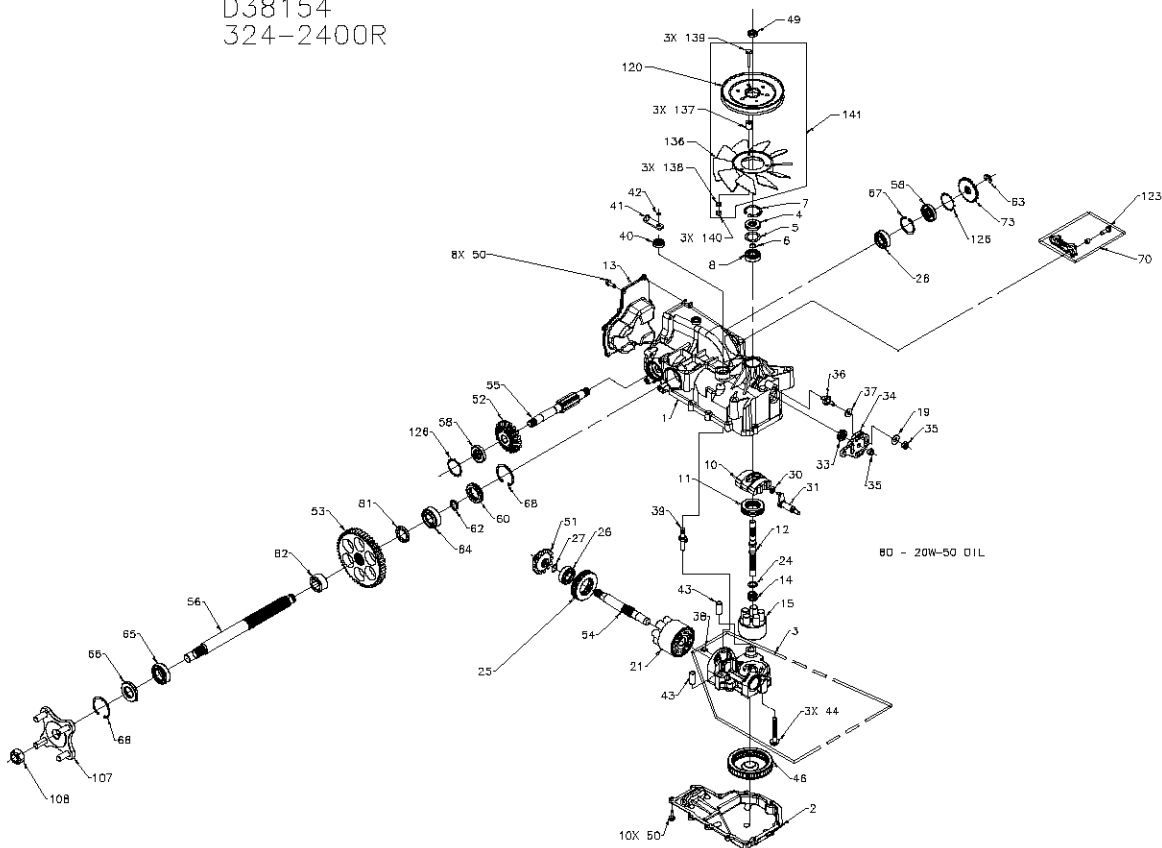

P, 1 of 2, 70657R-P2

D38154
324-2400R

ITEM NO.	HYDRO-GEAR PART NO.	QTY.	DESCRIPTION
1	70590	1	KIT, HOUSING-MAIN
		1	HOUSING, MAIN
		2	CRADLE BEARING
		1	LIP SEAL
		1	TRUNNION BUSHING
2	50890RM	1	LOWER HOUSING
3	70677	1	KIT, CENTER SECTION
		1	PLATE, BYPASS
		2	CHECK PLUG ASSEMBLY, .D27
		1	CENTER SECTION
		1	BUSHING .87 X 1.03 X .75
		3	BOLT, 3/8-24 X 2.5
4	9008000-0128	1	LIP SEAL
5	2003018	1	SPACER
6	2003016	1	WIRE RETAINING RING
7	2003052	1	RETAINING RING
8	2003043	1	BALL BEARING
10	2003087	1	VARIABLE SWASHPLATE
11	50551	1	THRUST BEARING 30 X 52 X 13
12	50005	1	INPUT SHAFT
13	50891RM	1	COVER-BACK
14	2003014	1	SPRING, BLOCK
15	70331	1	10cc CYLINDER BLOCK ASS'Y
		1	10cc CYLINDER BLOCK
		5	10cc PISTON SPRING
		5	PISTON SEAT WASHER
		5	10cc PISTON
19	44130	1	WASHER
21	70082	1	21cc CYLINDER BLOCK ASS'Y
		1	21cc CYLINDER BLOCK
		7	21cc PISTON SPRING
		7	PISTON SEAT WASHER
		7	10cc PISTON
24	2003017	1	WASHER, BLOCK THRUST
25	50552	1	THRUST BEARING 42 X 68 X 18
26	50315	2	BALL BEARING
27	2000022	1	WIRE RETAINING RING
30	2000015	1	SLOT GUIDE
31	50807	1	TRUNNION ARM
33	9008000-0126	1	LIP SEAL
34	50749	1	CONTROL ARM
35	50317	2	NUT
36	50426	1	STUD - SHORT 5/16-24
37	50281	1	FRICTION PUCK
38	70680	1	KIT, BYPASS PLATE
39	2003555	1	BYPASS ACTUATOR
40	45074	1	LIP SEAL
41	50270	1	BYPASS ARM
42	44670	1	RETAINING RING
43	50002	2	PIN
44	50016	3	SCREW
46	50990	1	FILTER
49	51244	1	HEX LOCK NUT 1/2-20 (NYLON INSERT)
50	50752	18	SCREW, 1/4-20 X .75 LONG
51	50744	1	14T BEVEL GEAR
52	50745	1	19T BEVEL GEAR

ITEM NO.	HYDRO-GEAR PART NO.	QTY.	DESCRIPTION
53	50746	1	53T SPUR GEAR
54	50757	1	MOTOR SHAFT
55	51298	1	BRAKE SHAFT
56	90748	1	AXLE SHAFT
58	51181	2	SEAL, LIP 17 X 40 X 7
60	50995	1	SEAL PLUG - SIDE
62	50759	1	RETAINING RING - AXLE
63	51109	1	RETAINING RING
64	50743	1	BEARING-BALL 20X47X14(6204)
65	50740	1	BEARING-BALL 25X47X12(6005)
66	50751	1	SEAL
67	50329	1	RETAINING RING
68	50760	2	RETAINING RING-AXLE
70	70391	1	LH BRAKE ARM SERVICE ASSEMBLY
		1	BRAKE ARM
		1	CLEVIS PIN
		1	BUSHING 0.255X0.381X0.330
		1	HEX WASHER HEAD SCREW, 1/4-20 X 7/8
73	50754	1	BRAKE DISC
80		78oz	20W-50 OIL
81	50842-2	1	AXLE BUSHING
82	50842-1	1	AXLE BUSHING
100	50828	1	SEALANT
107	70314	1	HUB ASSEMBLY
		1	HUB
		4	LUG BOLT
108	50863	1	NUT, HEX 3/4-16
120	51173	1	PULLEY, 5.5"
123	51076	1	HEX WASHER HEAD SCREW, 1/4-20 X 7/8
126	51318	2	RING, RETAINING
134	70553	1	KIT, SEAL
		1	SEAL, LIP 15 X 35 X 7
		1	RING, RETAINING
		1	SEAL, LIP 12 X 25 X 7
		1	SEAL, LIP 10 X 25 X 7
		1	RING, RETAINING
		2	SEAL, LIP 17 X 40 X 7
		1	SEAL, LIP 1.85 X .32
		1	RING, RETAINING
		1	RING, RETAINING .440 EXTERNAL
		1	SEAL, LIP .98 X 1.85 X .278
		1	RING, RETAINING
		2	RING, RETAINING
		2	RING, RETAINING
138	50307	1	FAN, 7" 10 BLADE
137	50259	3	SPACER
138	43177	3	LOCK WASHER 1/4 REGULAR
139	44276	3	BOLT, 1/4-20 X 1-1/2 W/PATCH
140	43178	3	HEX NUT 1/4-20NC
141	70418	1	KIT, FAN-PULLEY
		1	FAN, 7" 10 BLADE
		3	SPACER
		3	LOCK WASHER 1/4 REGULAR
		3	BOLT, 1/4-20 X 1-1/2 W/PATCH
		3	HEX NUT 1/4-20NC
		1	PULLEY, 5.5"

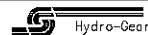

P, 2 of 2, 70657R-P2