

157981
314-3000

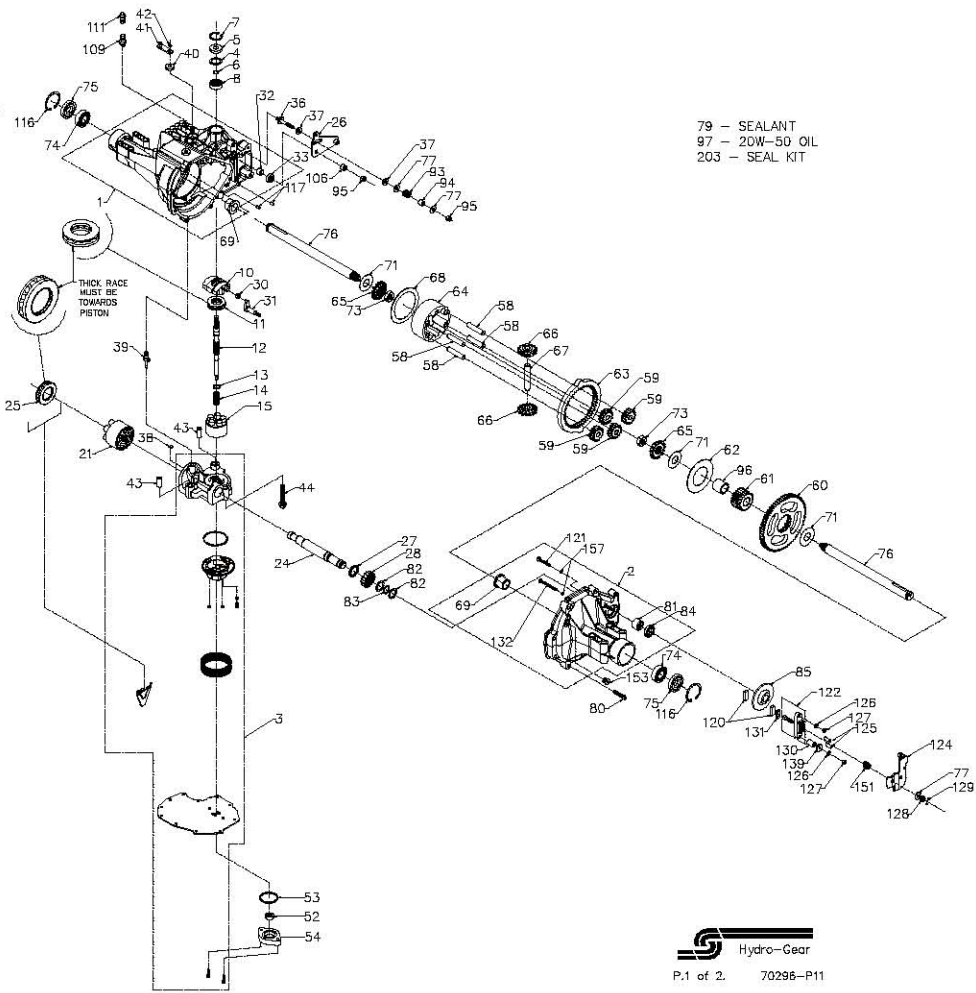

157981
314-3000

ITEM #	PART #	QTY	DESCRIPTION	ITEM #	PART #	QTY	DESCRIPTION	ITEM #	PART #	QTY	DESCRIPTION
1	70297	1	MAIN HOUSING ASSEMBLY	30	2000015	1	SLOT GUIDE	106	50850	1	SPACER, TRUNNION
		1	MAIN HOUSING	31	50807	1	TRUNNION ARM	109	70110	1	FITTING-O RING ASSEMBLY
		1	LIP SEAL	32	2003009	1	TRUNNION BUSHING	111	70109	1	CAP-VENT ASSEMBLY
		1	FLANGE BEARING	33	9008000-0126	1	LIP SEAL	116	50859	2	RETAINING RING
		1	TRUNNION BUSHING	36	50284	1	5/16-24 STUD	117	9004800-2506	2	STD HDLS PIN
		2	GRADLE BEARING	37	50281	2	PUCK, FRICTION	120	44132	2	PUCK, BRAKE
2	70298	1	R.H. HOUSING ASSEMBLY	38	70680	1	KIT, BYPASS PLATE	121	50874	1	RIB NECK BOLT 2"
		1	R.H. HOUSING	39	2003555	1	BYPASS ACTUATOR	122	70633	1	BRAKE YOKE ASSEMBLY
		1	FLANGE BEARING	40	45074	1	LIP SEAL	124	50916	1	ARM, BRAKE
		2	O RING	41	50270	1	BYPASS ARM	125	44127	2	PINS, BRAKE
		1	RIB NECK BOLT, 2"	42	44870	1	RETAINING RING	126	43177	2	LOCKWASHER, 1/4"
		1	RIB NECK BOLT, 3"	43	50002	2	PIN	127	43178	2	NUT, 1/4-20
		1	NEEDLE BEARING(SCE1412)	44	50016	3	SCREW	128	44142	1	NUT, CASTLE
		1	SEAL, LIP .875 X 1.38 X .25	52	50273	1	GEROTOR ASSEMBLY	129	44101	1	COTTER PIN
3	70448	1	KIT, MANIFOLD	53	9004101-1340	1	O-RING	130	23711	1	SPACER
		1	KIT, CENTER SECTION	54	50260	1	GEROTOR COVER	131	44134	1	PUCK PLATE
		1	CENTER SECTION	58	50776	4	PIN, CARRIER	132	50865	1	RIB NECK BOLT 3"
		1	BEARING .50 X .60 X .50	59	50763	4	15T PLANET GEAR	139	44278	1	WASHER, 7/800 X .265ID X .125 THK
		1	BUSHING .90 X 1.02 X .75	60	50646	1	67T SPUR GEAR	151	50919	1	COMP. SPRING, BRAKE ANTI-DRAG
		1	PLATE, BYPASS	61	50645	1	21 TOOTH SUN GEAR	153	9005110-5600	1	PLUG, STRAIGHT THREAD
		1	CHECK PLUG ASSEMBLY, .044	62	50769	1	PLANET THRUST PLATE	157	50977	2	O-RING, .070 X .239
		1	CHECK PLUG ASSEMBLY, NO BLEED	63	50764	1	51T RING GEAR	203	70492	1	KIT, SEAL
		2	CAPSCREW M6X1-22	64	50765	1	PLANETARY CARRIER			1	SEAL-UP 15X5X37
		1	COVER, LOWER	65	50647	2	MITER GEAR, DIFF. (SPLINED)			1	SEAL-UP 12X25X7
		1	KIT, FILTER	66	50648	2	MITER GEAR, DIFF.			1	SEAL-UP 10X25X7
		1	MANIFOLD, CHARGE	67	50766	1	SHAFT, DIFFERENTIAL			1	O-RING, .103X1.862
		1	RETAINER, MOTOR BEARING	68	50767	1	DIFF. THRUST PLATE			2	SEAL 25X52X10
		1	O RING .103X2.987	69	50768	2	FLANGE BEARING			1	LIP SEAL (.875 I.D.X1.3 O.D. X.25)
		1	SPRING, RELIEF	71	50788	3	WASHER 1.0 X 2.25 X .04			4	O-RING, .070X.239
		1	BALL 7/16	73	50791	2	HEX JAM NUT, 5/8-18			1	KIT, O-RING, MANIFOLD
		2	O-RING .070X.239	74	50771	2	BEARING, BALL 6205-1				
4	2003018	1	SPACER	75	50772	2	SEAL, 1" ID X 2.0472 X 0.375				
5	9008000-0128	1	SEAL-LIP	76	50663	2	SHAFT, AXLE				
6	2003016	1	WIRE RETAINING RING	77	44130	3	WASHER				
7	2003052	1	RETAINING RING	79	50928	1	GASKET MATERIAL				
8	2003043	1	BALL BEARING	80	50868	8	TORX HEAD SCREW, 5/16-18				
10	2003087	1	VARIABLE SWASHPLATE	81	44752	1	NEEDLE BEARING (SCE1412)				
11	50551	1	THRUST BEARING 30 X 52 X 13	82	50777	2	WASHER				
12	50795	1	INPUT SHAFT	83	50775	1	RETAINING RING				
13	2003017	1	BLOCK THRUST WASHER	84	50773	1	LIP SEAL (.875 I.D.X1.30 I.D.X.25)				
14	2003014	1	BLOCK SPRING	85	50779	1	BRAKE DISK				
15	70331	1	10cc CYLINDER BLOCK ASSEMBLY	96	50866	1	SLEEVE BEARING				
		5	10cc CYLINDER BLOCK	93	50277	1	SPRING, FRICTION PACK				
		5	10cc PISTON	94	50278	1	SPACER, FRICTION PACK				
		5	10cc PISTON SPRING	95	50108	2	HEX LOCK NUT 5/16-24				
		5	PISTON SEAT WASHER	97			20W-50 OIL				
21	70082	1	21cc CYLINDER BLOCK ASSEMBLY								
		1	21cc CYLINDER BLOCK								
		7	PISTON SEAT WASHER								
		7	21cc PISTON								
		7	21cc PISTON SPRING								
24	50662	1	OUTPUT (MOTOR) SHAFT								
25	50552	1	THRUST BEARING 42 X 68 X 16								
26	50857	1	CONTROL ARM								
27	50774	1	SPACER								
28	50661	1	15T PINION GEAR								