

D-3519-01
216-2500R
D-3519-02
216-2500L

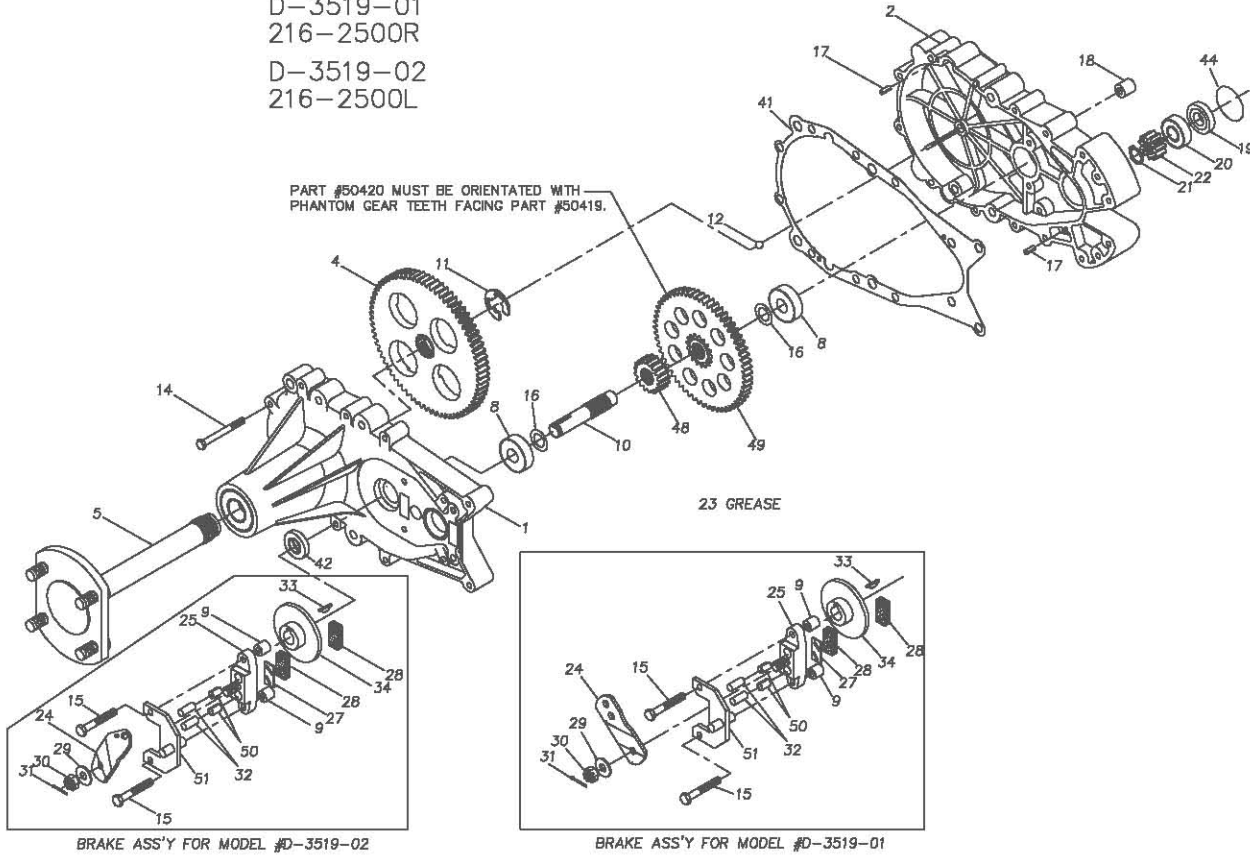

D-3519-01
216-2500R
D-3519-02
216-2500L

REF	PART NO.	QTY	DESCRIPTION	REF	PART NO.	QTY	DESCRIPTION
1	70272	1	ASS'Y, AXLE CARRIER HOUSING	27	44134	1	PLATE, PUCK
		1	AXLE CARRIER HOUSING	28	44132	2	PUCK, BRAKE
		1	BALL BEARING, 52MM X 25MM X 15MM	29	44130	1	WASHER, 7/16 X 7/8 OD X 0.06 HT
		1	FLANGE BEARING	30	44142	1	NUT, CASTLE 5/16-24 PL
		1	OIL SEAL, 1.25 OD X .625 ID	31	44101	1	PIN, COTTER
		1	OIL SEAL, 52MM X 25MM	32	44127	2	PIN, BRAKE ACTUATING
2	50855	1	HYDRO MOUNT HOUSING	33	44143	1	KEY, HI PRO 3/16 X 5/8
4	44358	1	SPLINED 72 TOOTH FINAL DRIVE GEAR	34	44090	1	DISC, BRAKE
5	62681	1	ASS'Y, AXLE	41	50223	1	GASKET, HSG
		1	AXLE SHAFT	42	50263	1	OIL SEAL, 1.25 X .625
		4	LUG BOLT	44	50267	1	O-RING
8	50625	2	BALL BEARING .625ID X 1.57 X .47	48	50419	1	17 TOOTH GEAR
9	23770	2	BRAKE SPACER	49	50420	1	60 TOOTH GEAR
10	44351	1	BRAKE SHAFT (SPLINED)	50	50860	2	DU BEARING
11	44359	1	E-RING	51	50862	1	BRAKE STOP PLATE
12	9001214-3700	1	BALL, 3/8" DIAMETER				
14	44366	10	BOLT, 1/4-20 X 2-1/2"				
16	50629	2	WASHER, 5/8ID X 1.0 OD X .01 THK				
17	44269	2	PIN, SPRING 3/16" X 1/2" LONG				
18	23749	2	MOUNTING SPACER				
19	44355	1	BEARING SPACER				
20	44232	1	BALL BEARING 15 MM X 35 MM X 11 MM				
21	44354	1	RETAINING RING				
22	44353	1	11 TOOTH INPUT GEAR				
23	50416	2	GREASE(10 OZ TUBE)				
24	44094	1	ARM, BRAKE ACTUATOR (LH ASSY)				
-	44613	1	ARM, BRAKE ACTUATOR (RH ASSY)				
25	70274	1	ASS'Y, BRAKE YOKE				
		1	BRAKE YOKE				
		1	SQUARE HEAD BOLT				