

NOTICE - THIS DRAWING CONTAINS PROPRIETARY INFORMATION OF HYDRO-GEAR, INC. WITHOUT RECEIPT FOR POSSESSION THEREOF CONVEYS ANY RIGHT TO REPRODUCE, USE, OR DISCLOSE, IN WHOLE OR PART, ANY SUCH INFORMATION WITHOUT WRITTEN AUTHORIZATION FROM HYDRO-GEAR, INC.

PART NO.

CHANGES

GREASE SEAL MUST BE FLUSH TO 0.01 DEPRESSED

NEEDLE BEARING 0.005/0.015 DEPRESSED THIS SIDE

GREASE SEAL EDGE MUST PROJECT OUTWARD

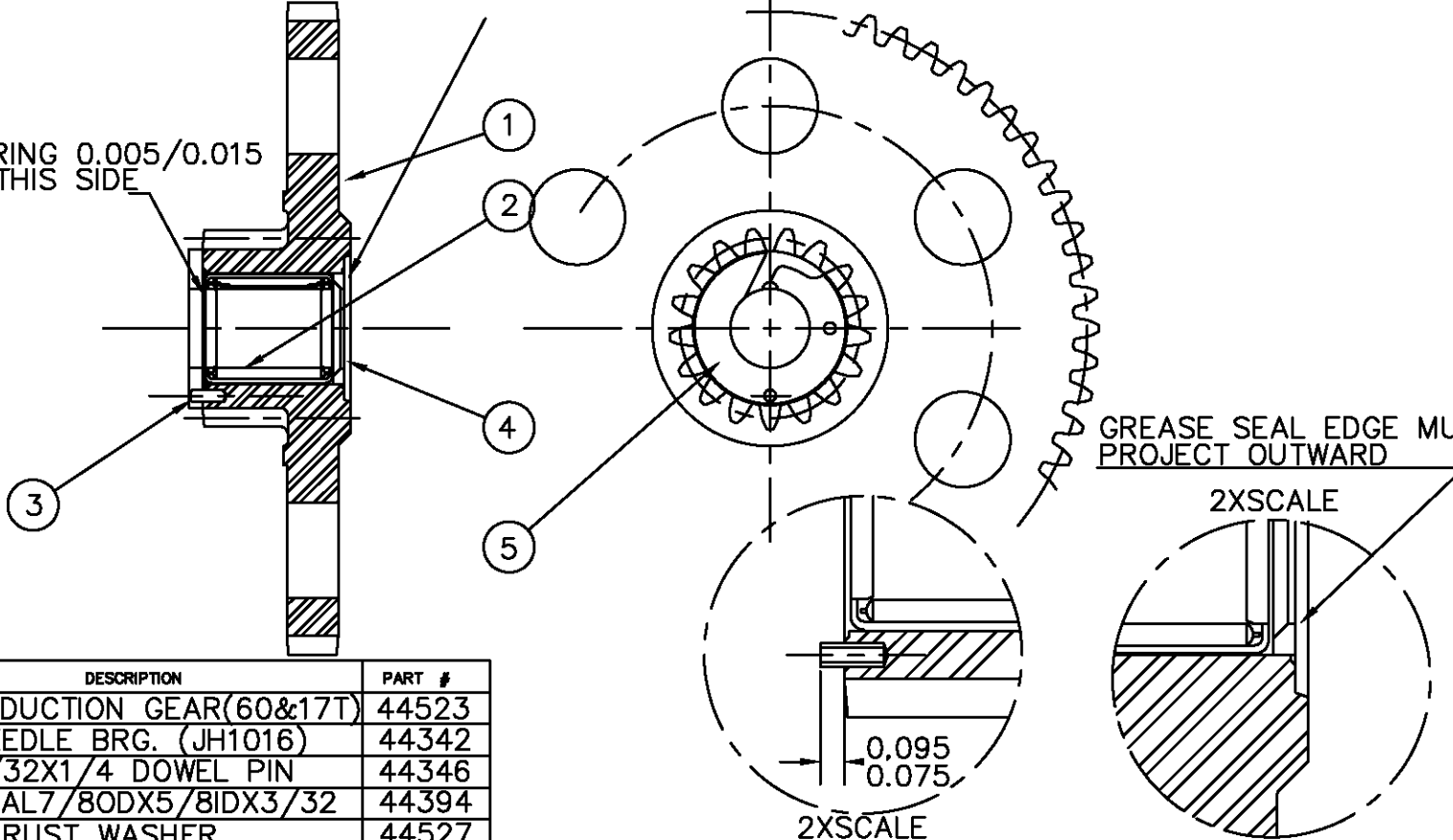

ASSY#	ITEM	QTY.	DESCRIPTION	PART #	
	1	52	1	REDUCTION GEAR(60&17T)	44523
	2	47	1	NEEDLE BRG. (JH1016)	44342
	3	60	1	3/32X1/4 DOWEL PIN	44346
	4	61	1	SEAL7/8ODX5/8IDX3/32	44394
	5	48	1	THRUST WASHER	44527

PRODUCTION RELEASE  
DATE 12/08/89  
APPR. RHAUSER

Ⓟ CHANGES

NEW FRAME  
08/09/91 MAD

Ⓢ1  
ADD'D #49&44371) &  
59(44125).  
ECN #3924  
08/02/98 S POPE

Ⓟ2  
REM'D ITEMS  
49 & 59  
ADD'D ASSY#  
ECN#10894  
4-7-03 MS

  
Hydro-Gear  
P.O. BOX 530 SULLIVAN, IL 61951  
PHONE (217) 728-2581

QTY PER ASS'Y - (1)

	DATE	NAME
DRAWN	11/13/89	S POPE
CHECKED		
APPR.		

TOLERANCES UNLESS SPECIFIED  
.0 ±.020  
.00 ±.010  
.000 ±.005  
.0000 ±.0005  
ANGLE ±1°

MATERIAL  
  
FINISH

SCALE FULL  

NAME REDUCTION GEAR ASSY.  
USED ON 210-1000/210-2000

FORMER PART NO.

PART NO. 62758  
CHG Ⓟ2