

01008192  
344-2400L

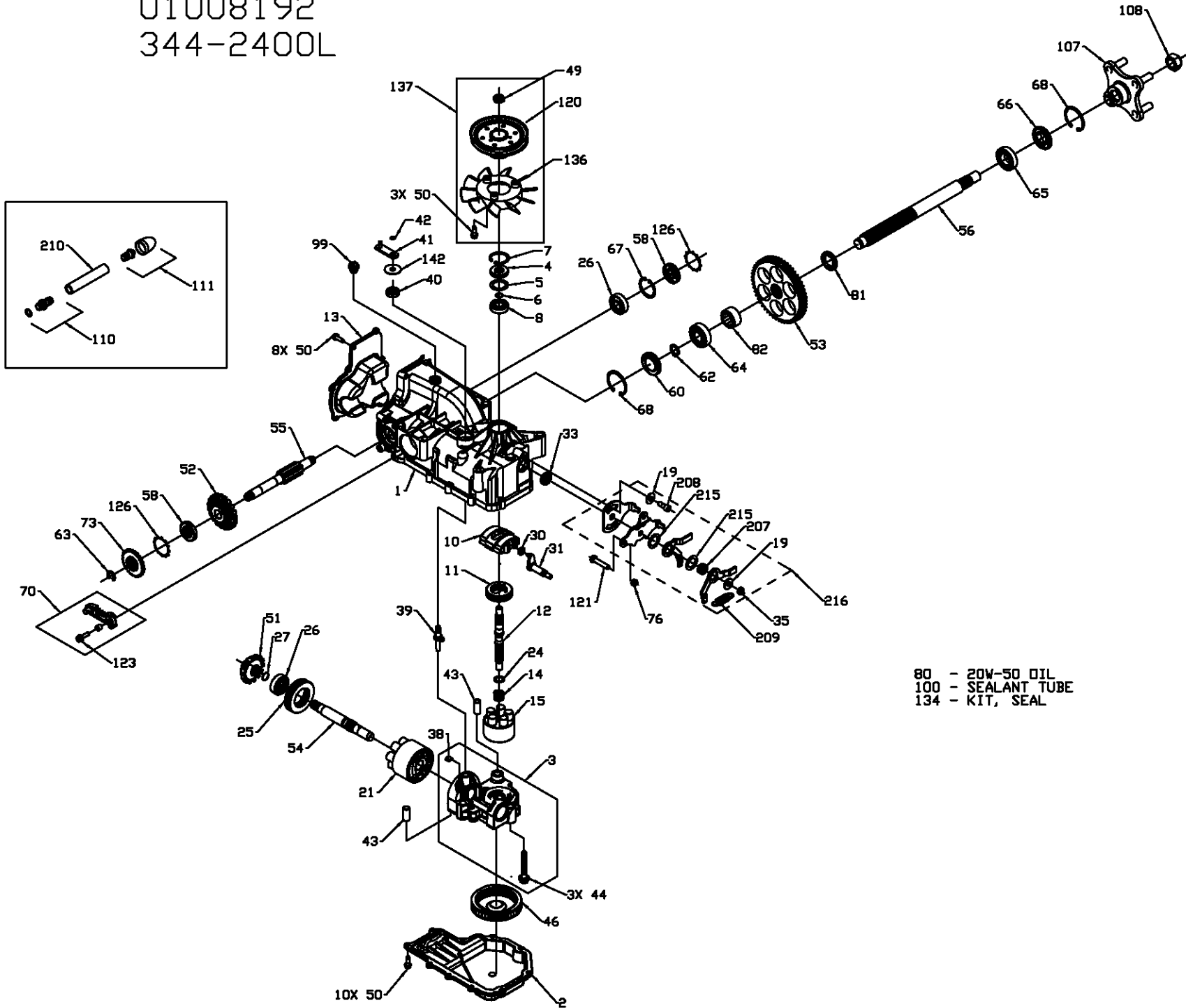

80 - 20W-50 OIL  
100 - SEALANT TUBE  
134 - KIT, SEAL

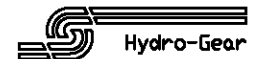

01008192  
344-2400L

ITEM #	PART #	QTY	DESCRIPTION	ITEM #	PART #	QTY	DESCRIPTION	ITEM #	PART #	QTY	DESCRIPTION
1	70627	1	KIT, HOUSING-MAIN	43	50002	2	PIN, HOLLOW .39 X .5 X 1	126	51316	2	RING, RETAINING
		1	HOUSING, MAIN	44	50016	3	BOLT, HEX FLANGE 3/8-24 X 2.5	134	70553	1	KIT, SEAL
		2	CRADLE BEARING	46	50990	1	FILTER			1	SEAL, LIP 15 X 35 X 7
		1	TRUNNION BUSHING	49	51244	1	HEX LOCK NUT 1/2-20 (NYLON INSERT)			1	RING, RETAINING 37 INT
		1	SEAL, LIP 12 X 25 X 7	50	50752	21	SCREW, 1/4-20 X .75			1	SEAL, LIP 12 X 25 X 7
		1	SCREW, HFHC 1/4-28 X 7/8 (PATCH)	51	50744	1	14T BEVEL GEAR			1	SEAL, LIP 10 X 25 X 7
2	50890RM	1	LOWER HOUSING	52	50745	1	19T BEVEL GEAR			1	RING, RETAINING .31 EXT
3	70677	1	KIT, CENTER SECTION	53	50746	1	53T SPUR GEAR			18	HFHCS 1/4-20 X .75
		1	CENTER SECTION	54	50757	1	SHAFT, MOTOR			1	SEAL PLUG
		1	BUSHING .67 X 1.03 X .75	55	51298	1	SHAFT, BRAKE			1	RING, RETAINING .75 EXT
		1	PLATE, BYPASS	56	50748	1	SHAFT, AXLE			1	RING, RETAINING .440 EXT
		3	BOLT, HEX FLANGE 3/8-24 X 2.5	58	51161	2	SEAL, LIP 17 X 40 X 7			1	SEAL, LIP 25 X 47 X 7
		2	CHECK PLUG ASSEMBLY, .027	60	50995	1	SEAL PLUG - SIDE			1	RING, RETAINING 1.56 INT
4	9008000-0128	1	SEAL, LIP 15 X 35 X 7	62	50759	1	RING, RETAINING - AXLE	136	51365	1	FAN, 6", 10 BLADE
5	2003018	1	SPACER	63	51109	1	RING, RETAINING	137	70591	1	KIT, FAN-PULLEY
6	2003016	1	RING, WIRE RETAINING	64	50743	1	BEARING-BALL 20X47X14(6204)			3	SCREW, 1/4-20 X .75
7	2003052	1	RING, RETAINING	65	50740	1	BEARING-BALL 25X47X12(6005)			1	FAN, 6", 10 BLADE
8	2003043	1	BALL BEARING	66	50751	1	SEAL, LIP 25 X 47 X 7			1	HEX LOCK NUT 1/2-20 (NYLON INSERT)
10	2003087	1	VARIABLE SWASHPLATE	67	50329	1	RING, RETAINING			1	PULLEY, Ø4.5 X 1.625
11	50551	1	THRUST BEARING 30 X 52 X 13	68	50760	2	RING, RETAINING -AXLE	142	51813	1	WASHER, .39 X 1.27 X .05
12	50005	1	SHAFT, INPUT	70	70391	1	ASSEMBLY, BRAKE ARM SERVICE	207	51396	1	SPACER, RTN
13	50891RM	1	COVER-BACK			1	ARM, BRAKE ZINC	208	51400	1	SHCS 5/16-24 X .75 (PATCH)
14	2003014	1	SPRING, BLOCK			1	CLEVIS PIN	209	51399	1	SPRING, EXTENSION
15	70331	1	10cc CYLINDER BLOCK ASS'Y			1	BUSHING .255 X .394 X .330	210	51401	1	HOSE .5 X 4
		1	10cc CYLINDER BLOCK			1	SCREW, HFHC 1/4-28 X 7/8 (PATCH)	215	51408	2	WASHER, PLASTIC 1.19 X .7
		5	10cc PISTON SPRING			1	BRAKE DISC	216	70609	1	KIT, RTN SCISSOR
		5	PISTON SEAT WASHER	73	50754	1	NUT, HEX 5/16-18			2	WASHER, .34 X .88 X .06
		5	10cc PISTON	76	43083	1	20W-50 OIL			1	NUT, HEX LOCK 5/16-24 UNJF
19	44130	2	WASHER, .34 X .88 X .06	80		79oz	AXLE BUSHING			1	ARM, RTN
21	70082	1	21cc CYLINDER BLOCK ASS'Y	81	50942-2	1	AXLE BUSHING			1	ARM, RTN SCISSOR, INNER
		1	21cc CYLINDER BLOCK	82	50942-1	1	AXLE BUSHING			1	ARM, RTN SCISSOR, OUTER
		7	21cc PISTON SPRING	99	9005200-5600	1	PLUG, PLASTIC			1	ARM, CONTROL
		7	PISTON SEAT WASHER	100	50928	1	SEALANT TUBE, 10.3 oz			1	SPACER, RTN
		7	21cc PISTON	107	70314	1	HUB ASSEMBLY			1	SPRING, EXTENSION
24	2003017	1	WASHER, BLOCK THRUST			1	HUB			1	SHCS 5/16-24 X .75 (PATCH)
25	50552	1	THRUST BEARING 42 X 68 X 16			1	LUG BOLT			2	WASHER, PLASTIC 1.19 X .7
26	50315	2	BALL BEARING	108	50863	1	NUT, HEX 3/4-16				
27	2000022	1	RING, WIRE RETAINING	110	70110	1	FITTING O-RING ASSEMBLY				
30	2000015	1	SLOT GUIDE			1	PLASTIC HOSE FITTING				
31	50807	1	TRUNNION ARM			1	O-RING				
33	9008000-0126	1	SEAL, LIP 12 X 25 X 7	111	70921	1	CAP VENT ASSEMBLY				
35	50108	1	NUT, HEX LOCK 5/16-24 UNJF			1	CAP-POPPET VALVE				
38	70680	1	KIT, BYPASS PLATE			1	PLASTIC VENT				
		1	PLATE, BYPASS (BREAD)	120	50302	1	PULLEY, Ø4.5 X 1.625				
		1	PLATE, BYPASS	121	51753	1	BOLT, 5/16-18 X 1.50				
39	2003555	1	BYPASS ACTUATOR	123	51576	1	SCREW, HFHC 1/4-28 X 7/8 (PATCH)				
40	45074	1	SEAL, LIP 10 X 25 X 7								
41	50270	1	ARM, BYPASS								
42	44870	1	RING, RETAINING								

