

70703  
328-0510

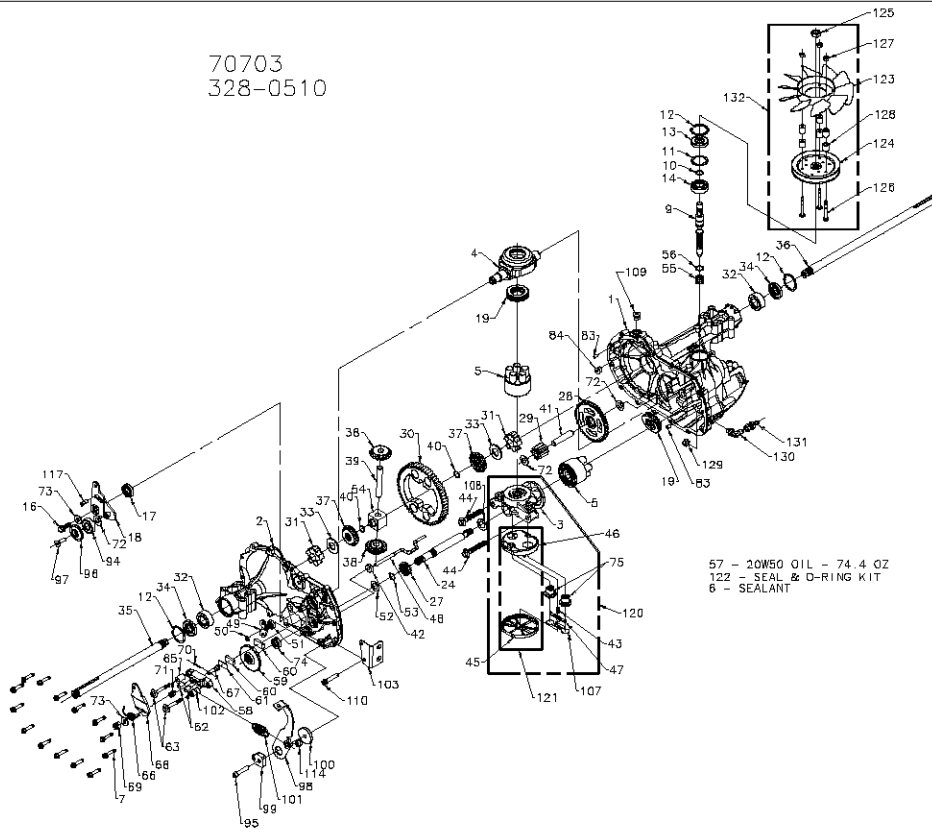

P.1 of 2. 70703-P

70703  
328-0510

ITEM	PART NUMBER	QTY	DESCRIPTION
1	70718	1	MAIN HOUSING, ASSEMBLY
		1	MAIN HOUSING, MACHINED
2	70483	1	BUSHING .065 X .985 X .790
		1	SIDE HOUSING, ASSEMBLY
		1	SIDE HOUSING, MACHINED
		1	BUSHING .065 X .985 X .790
3	70477	1	BUSHING .024 X .719 X .582
		1	CENTER SECTION, ASSEMBLY
		1	CENTER SECTION, MACHINED
		1	BUSHING .707 X .788 X .591
4	51048	1	SWASHPLATE, TRUNNION MACHINED
5	70331	2	BLOCK - ASSEMBLY
		5	PISTON
		5	SPRING, COMPRESSION
		5	WASHER - THRUST
6	50828	10.5 OZ	SEALANT
7	51180	14	HEX FLANGE SCREW 1/4-20 X 1.25
9	51082	1	SHAFT, INPUT
10	2000022	1	RING - RETAINING
11	50851	1	SPACER
12	50329	3	RING - RETAINING
13	51151	1	SEAL, LIP .67 X 1.58 X .278
14	60315	1	BALL BEARING 17MM I.D X .90MM O.D X 12MM
16	51084	1	HEX FLANGE HEAD SCREW 5/16-24 X 0.75
17	51140	1	LIP SEAL 18 X 32 X 7
18	51121	1	ARM, CONTROL
19	50551	2	BEARING, 3025X13 THRUST
24	50986	1	SHAFT, MOTOR
27	51130	1	GEAR - PINNION, 1ST
28	51129	1	10T/48T GEAR
28	51043	1	GEAR, 10T JACKSHAFT
30	51044	1	80T BULL GEAR
31	51088	2	SLEEVE BEARING .75 X 1.750 X .625
32	51089	2	SLEEVE BEARING (OUTBOARD) .75 X 1.575 X .625
33	44875	2	WASHER, 3/4 ID X 1-1/2 OD X .13 THK
34	51066	2	LIP SEAL AXLE SEAL
35	51354	1	SHAFT, AXLE .76 X 12.14 (KEY, RH)
36	51353	1	SHAFT, AXLE .75 X 17.74 (KEY, LH)
37	44096	2	MILNER GEAR (SPLINED)
38	44097	2	MILNER GEAR 15T (0.5 ID)
38	50146	1	SHAFT
40	44871	2	RING, SPIRAL RETAINING
41	51083	1	PIN, JACKSHAFT
42	51100	1	MACKET, RING
43	51136	1	SPRING, BYPASS
44	50016	2	HYDRO MTC SCREW 3/8-24 X 2.5 LONG
45	51132	1	FILTER
46	51133	1	BASE, FILTER
47	51091	1	ACTUATOR, BYPASS
48	51098	1	ROD, BYPASS ACTUATOR
48	51135	1	ARM, BYPASS
50	51116	1	RETAINING RING D.250 EXTERNAL
51	51081	1	SEAL, LIP .741 X .250 X .250 TC
52	44371	1	FLAT WASHER, 5/8 ID X 1.0 OD X .05 THK
53	44145	1	RETAINING RING
54	51071	1	BEARING, CENTER BLOCK
55	2003014	1	SPRING - HELICAL COMPRESSION
56	2003017	1	WASHER
57		74.4 OZ	20W-50 OIL
58	44092	1	BRAKE YOKE
59	51072	1	ROTOR, BRAKE
60	44132	2	BRAKE PLUCK
61	44134	1	PLUCK PLATE
62	44137	2	BRAKE ACTUATING PIN
63	51146	2	HFCHS 1/4-20 X 2 W/PATCH, SPECIAL FLANGE
65	23711	1	SPACER
66	51345	1	SPRING, BRAKE ARM BLAS

ITEM	PART NUMBER	QTY	DESCRIPTION
67	44138	1	SQ. HD. BOLT 5/16-24- RIBBED
68	44094	1	ARM, BRAKE
68	44142	1	SLOTTED HEX NUT 5/16-24
70	44101	1	CENTER PIN 3/32 X 3/4
71	50819	1	COMPRESSION SPRING BRAKE ANTI-DRAW
72	50132	3	WASHER, HT .5 I.D. X 1.0 O.D. X .032
73	44130	2	FLAT - WASHER 11/32 I.D. X 7/8 O.D
74	44781	1	OIL SEAL .625 X 1.0 X .25
75	51084	2	CHECK PLUG ASSEMBLY .027, WASHER
83	9004800-2506	2	PIN, STANDARD HEADLESS
84	8005110-5000	1	PLUG, SAE #5
94	44147	1	BALL BEARING .62 ID X 1.38 X .44
95	90957	1	SOCKET HEAD CAP SCREW, 5/16-24 X 1-1/2
98	61300	1	SPACER, LOADING
97	50870	1	SCREW, SFCHS
98	51120	1	ARM, RETURN
98	61087	1	PLUCK, ADJUSTING
100	51122	1	WASHER, 1.60 OD X .324 ID X .238 THK
101	51131	1	SPRING, EXTENSION
102	51123	1	SPACER, .580 OD X .260 ID X .870
103	61528	1	BRACKET, TORQUE
107	51134	1	DEFLECTOR
108	51089	1	WASHER, MOTOR SHAFT .71 ID X 1.16 OD X .04 THK
109	8005110-5000	1	PLUG, SAE #5
110	50868	1	TORX HEAD SCREW, 5/16-18 T.F.
114	51184	1	SPRING GUIDE
117	61124	1	PIN, COIL SPRING 3/16 X .75
120	70486	1	CENTER SECTION - FILTER - BYPASS ASSEMBLY
		1	BASE FILTER
		2	CHECK PLUG ASSEMBLY
		1	SPRING, BYPASS
		1	ACTUATOR, BYPASS
		1	DEFLECTOR
		1	FILTER
121	70466	1	FILTER ASSEMBLY
		1	FILTER
		1	BASE, FILTER
122	70463	1	SEAL - O-RING KIT
		1	SEAL, LIP .67 X 1.58 X .278
		1	LIP SEAL 18 X 32 X 7
		2	LIP SEAL .750 X 1.577 X .25
		1	SEAL, LIP .741 X .250 X .250 TC
		1	OIL SEAL .625 X 1.0 X .25
		1	O-RING .07 X .301 ID (NOT USED)
123	60827	1	FAN 7.0 (10 BLADE)
124	51182	1	PULLEY #4.40 X .665
125	44133	1	NUT, HEX LOCK 1/2-20 W/PATCH
126	44300	3	BOLT, 1/4-20 X 2.0 W/PATCH
127	43178	3	NUT, HEX 1/4-20
128	50259	6	SPACER
128	51487	1	NUT, HEX 7/16-20
130	51324	1	FITTING, 90° SAE #4 7/16-20
131	61527	1	FITTING, #4 - 37 TUBE 1/4 BARB
132	70711	1	KIT, FAN/PULLEY
		1	FAN 7.0 (10 BLADE)
		1	PULLEY #4.40 X .665
		1	NUT, HEX LOCK 1/2-20 W/PATCH
		3	BOLT, 1/4-20 X 2.0 W/PATCH
		3	NUT, HEX 1/4-20
		6	SPACER



P.2 of 2. 70703-P