

100-7360
319-2400R

80 - 20W-50 OIL
100 - SEALANT
134 - SEAL KIT

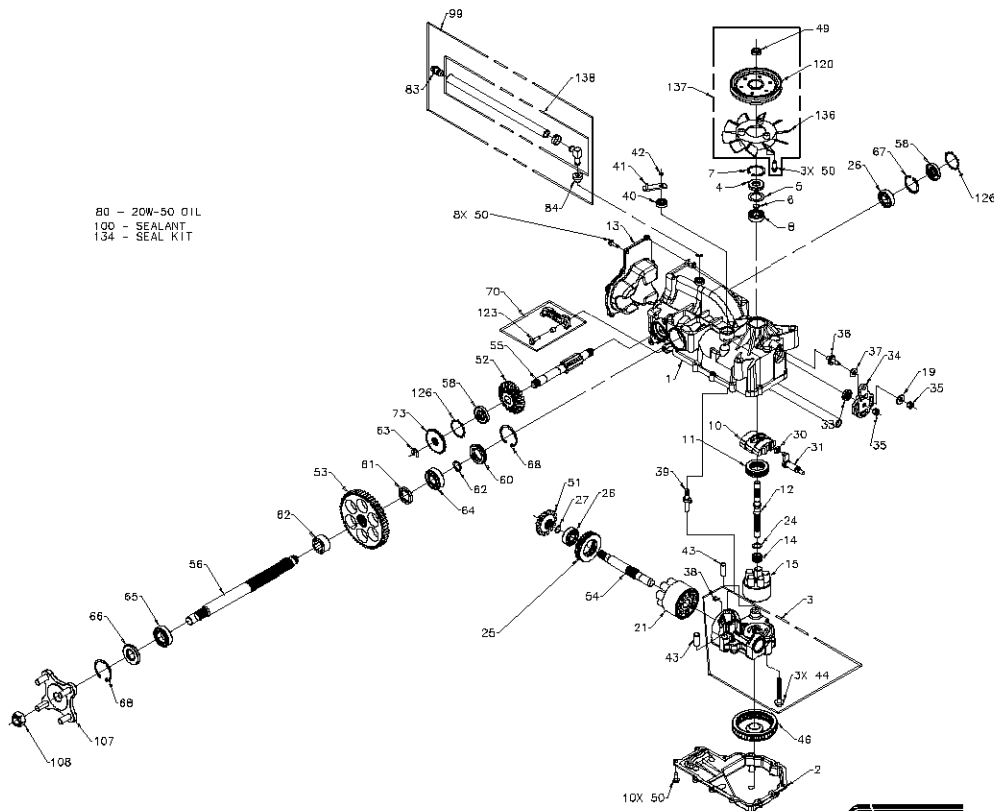

P.1 of 2. 70587R-P3

100-7360
319-2400R

ITEM #	PART #	QTY	DESCRIPTION	ITEM #	PART #	QTY	DESCRIPTION
1	70590	1	KIT, HOUSING-MAIN	54	50757	1	MOTOR SHAFT
		1	HOUSING, MAIN	55	51298	1	BRAKE SHAFT
		2	CRADLE BEARING	56	50748	1	AXLE SHAFT
		1	LIP SEAL	58	51161	2	SEAL, LIP 17 X 40 X 7
2	50890RM	1	TRUNNION BUSHING	60	50985	1	SEAL PLUG - SIDE
3	70667	1	LOWER HOUSING	62	50759	1	RETAINING RING - AXLE
		1	KIT, CENTER SECTION	63	51109	1	RETAINING RING
		1	CENTER SECTION	64	50743	1	BEARING-BALL 20X47X14(6204)
		1	BUSHING .67 X 1.03 X .75	65	50740	1	BEARING-BALL 25X47X12(6005)
		1	PLATE, BYPASS	66	50751	1	SEAL
		3	SCREW, 3/8-24 X 2.5	67	50329	1	RETAINING RING
		2	CHECK PLUG ASSEMBLY, .027	68	50760	2	RETAINING RING-AXLE
4	900800D-0126	1	LIP SEAL	70	70391	1	LH, BRAKE ARM SERVICE ASSEMBLY
5	2003018	1	SPACER			1	BRAKE ARM
6	2003016	1	WIRE RETAINING RING			1	CLEVIS PIN
7	2003052	1	RETAINING RING			1	BUSHING .255 X .381 X .330
8	2003043	1	BALL BEARING	73	50754	1	HEX WASHER HEAD SCREW, 1/4-20 X 7/8
10	2003087	1	VARIABLE SHIMSPATE	80		79oz	BRAKE OIL
11	50551	1	THRUST BEARING 30 X 92 X 13	81	50942-2	1	AXLE BUSHING
12	50005	1	INPUT SHAFT	82	50942-1	1	AXLE BUSHING
13	50891RM	1	COVER-BACK	83	70109	1	CAP-VENT ASSEMBLY
14	2003014	1	SPRING, BLOCK	84	50133	1	VENT BUSHING
15	70331	1	10cc CYLINDER BLOCK ASS'Y	99	70592	1	KIT, BREATHER
		5	10cc CYLINDER BLOCK			1	CAP-VENT ASSEMBLY
		5	10cc PISTON SPRING			1	BUSHING, VENT
		5	PISTON SEAT WASHER			1	HOSE/FITTING ASSEMBLY
		5	10cc PISTON	100	50928	1	SEALANT
19	44130	1	WASHER	107	70314	1	HUB ASSEMBLY
21	70082	1	21cc CYLINDER BLOCK ASS'Y			1	HUB
		1	21cc CYLINDER BLOCK			4	LUG BOLT
		7	21cc PISTON SPRING			1	NUT, HEX 3/4-16
		7	PISTON SEAT WASHER	108	50863	1	PULLEY, 4.5
		7	21cc PISTON	120	50302	1	HEX WASHER HEAD SCREW, 1/4-20 X 7/8
24	2003017	1	WASHER, BLOCK THRUST	123	51076	1	RING, RETAINING
25	50552	1	THRUST BEARING 42 X 68 X 16	126	51316	2	RING, RETAINING
26	50315	2	BALL BEARING	134	70553	1	KIT, SEAL
27	2000022	1	WIRE RETAINING RING			1	SEAL, LIP 15 X 35 X 7
30	2000015	1	SLOT GUIDE			1	RING, RETAINING
31	50807	1	TRUNNION ARM			1	SEAL, LIP 12 X 25 X 7
33	900800D-0126	1	LIP SEAL			1	SEAL, LIP 10 X 25 X 7
34	50749	1	CONTROL ARM			2	RING, RETAINING
35	50317	2	NUT			1	SEAL, LIP 17 X 40 X 7
36	50426	1	STUD - SHORT 5/16-24			1	SEAL, LIP 1.85 X .32
37	50281	1	FRICITION PUCK			1	RING, RETAINING
38	70680	1	KIT, BYPASS PLATE			1	RING, RETAINING .440 EXTERNAL
39	2003555	1	BYPASS ACTUATOR			1	SEAL, LIP .98 X 1.85 X .276
40	45074	1	LIP SEAL			2	RING, RETAINING
41	50270	1	BYPASS ARM			2	RING, RETAINING
42	44870	1	RETAINING RING			2	SEAL, LIP 17 X 40 X 5
43	50002	2	PIK	138	51365	1	FAN, 6", 10 BLADE
44	50016	3	SCREW	137	70591	1	KIT, FAN-PULLEY
46	50990	1	FILTER			1	WASHER, .331 X 1.250 X .082 (BELLEVILLE)
49	51244	1	HEX LOCK NUT 1/2-20 (NYLON INSERT)			1	FAN, 6", 10 BLADE
50	50752	21	SDREW, 1/4-20 X .75 LONG			1	HEX LOCK NUT 1/2-20 (NYLON INSERT)
51	50744	1	14T BEVEL GEAR			1	PULLEY, 4.5
52	50745	1	19T BEVEL GEAR	138	70588	1	HOSE/FITTING ASSEMBLY
53	50746	1	53T SPUR GEAR			1	METAL FITTING
						1	PINCH CLAMP, SINGLE EAR
						1	1/2" HOSE X 12.0" LONG

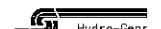
P.2 of 2. 70587R-P3