

100-7361  
319-2400L

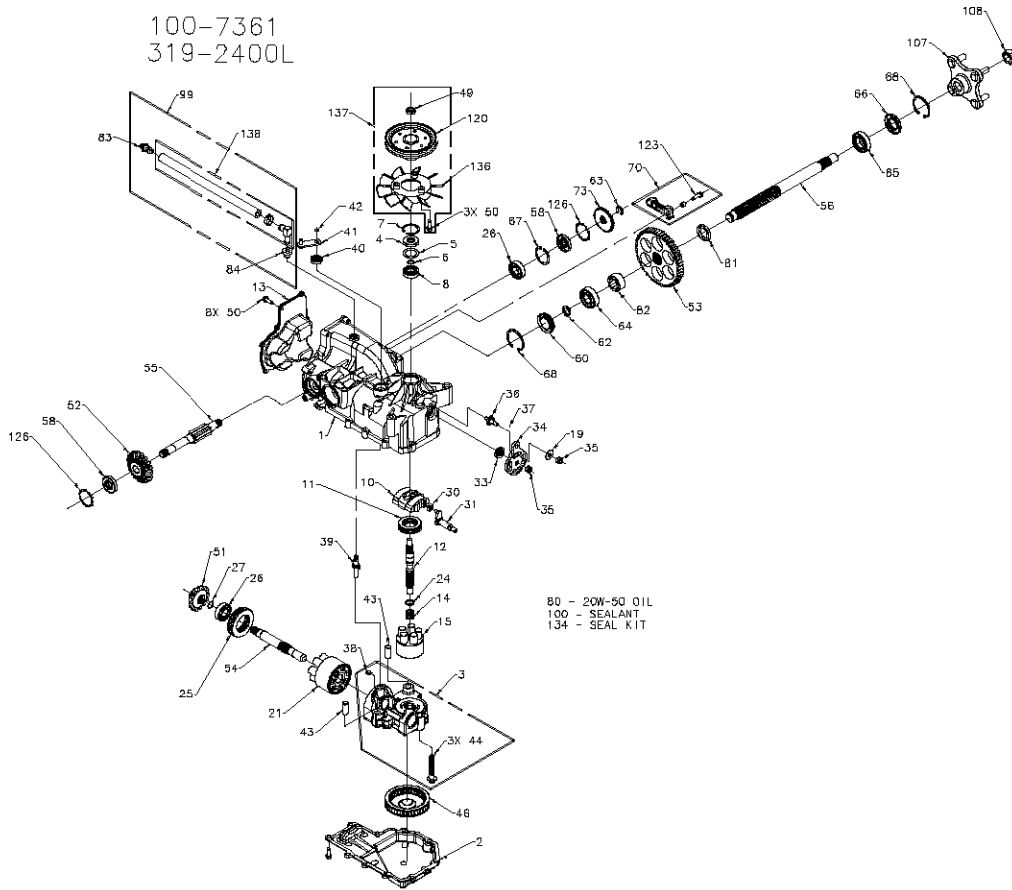

100-7361  
319-2400L

ITEM #	PART #	QTY	DESCRIPTION	ITEM #	PART #	QTY	DESCRIPTION
1	70590	1	KIT, HOUSING-MAIN	55	51298	1	BRAKE SHAFT
		1	HOUSING, MAIN	56	50748	1	AXLE SHAFT
		1	CRADLE BEARING	58	51161	2	SEAL, LIP 17 X 40 X 7
		1	LIP SEAL	60	50995	1	SEAL PLUG - SIDE
2	50890RM	1	TRUNNION BUSHING	62	50759	1	RETAINING RING - AXLE
3	70667	1	LOWER HOUSING	63	51109	1	RETAINING RING
		1	KIT, CENTER SECTION	64	50743	1	BEARING-BALL 20X47X14(6204)
		1	CENTER SECTION	65	50740	1	BEARING-BALL 25X47X12(6005)
		1	BUSHING .67 X 1.03 X .75	66	50751	1	SEAL
		1	PLATE, BYPASS	67	50328	1	RETAINING RING
		3	SCREW, 3/8-24 X 2.5	68	50760	2	RETAINING RING-AXLE
		2	CHECK PLUG ASSEMBLY, .027	70	70391	1	LH, BRAKE ARM SERVICE ASSEMBLY
4	900800D-0128	1	LIP SEAL			1	BRAKE ARM
5	2003018	1	SPACER			1	CLEVIS PIN
6	2003016	1	WIRE RETAINING RING			1	BUSHING 255 X .361 X .330
7	2003052	1	RETAINING RING	73	50754	1	HEX WASHER HEAD SCREW, 1/4-20 X 7/8
8	2003043	1	BALL BEARING	79a		1	BRAKE DISC
10	2003057	1	VARIABLE SWASHPLATE	81	50942-2	1	AXLE BUSHING
11	50551	1	THRUST BEARING 30 X 52 X 13	82	50942-1	1	AXLE BUSHING
12	50005	1	INPUT SHAFT	83	70109	1	CAP-VENT ASSEMBLY
13	50091RM	1	COVER-BACK	84	50133	1	VENT BUSHING
14	2003014	1	SPRING, BLOCK	99	70592	1	KIT, BREATHER
15	70331	1	10cc CYLINDER BLOCK ASS'Y			1	CAP-VENT ASSEMBLY
		1	10cc CYLINDER BLOCK			1	BUSHING, VENT
		5	10cc PISTON SPRING			1	HOSE/FITTING ASSEMBLY
		5	PISTON SEAT WASHER	100	50928	1	SEALANT
		5	10cc PISTON	107	70314	1	HUB ASSEMBLY
19	44130	1	WASHER			1	HUB
21	70082	1	21cc CYLINDER BLOCK ASS'Y			4	LUG BOLT
		1	21cc CYLINDER BLOCK	108	50863	1	NUT, HEX 3/4-16
		7	21cc PISTON SPRING	120	50302	1	PULLEY, 4.5
		7	PISTON SEAT WASHER	123	51076	1	HEX WASHER HEAD SCREW, 1/4-20 X 7/8
		7	21cc PISTON	126	51316	2	RING, RETAINING
24	2003017	1	WASHER, BLOCK THRUST	134	70553	1	KIT, SEAL
25	50552	1	THRUST BEARING 42 X 88 X 16			1	SEAL, LIP 15 X 35 X 7
26	50315	2	BALL BEARING			1	RING, RETAINING
27	2000022	1	WIRE RETAINING RING			1	SEAL, LIP 12 X 25 X 7
30	2000015	1	SLOT GUIDE			1	SEAL, LIP 10 X 25 X 7
31	50807	1	TRUNNION ARM			1	RING, RETAINING
33	900800D-0126	1	LIP SEAL			1	RING, RETAINING
34	50749	1	CONTROL ARM			2	SEAL, LIP 17 X 40 X 7
35	50317	2	NUT			1	SEAL, LIP 1.85 X .32
36	50426	1	STUD - SHORT 5/16-24			1	RING, RETAINING
37	50281	1	FRICITION PUCK			1	RING, RETAINING .440 EXTERNAL
38	70680	1	KIT, BYPASS PLATE			1	SEAL, LIP .58 X 1.85 X .276
39	2003555	1	BYPASS ACTUATOR			1	RING, RETAINING
40	45074	2	LIP SEAL			2	RING, RETAINING
41	50270	1	BYPASS ARM			2	RING, RETAINING
42	44870	1	RETAINING RING			2	SEAL, LIP 17 X 40 X 5
43	50002	2	PIN	136	51365	1	FAN, 6", 10 BLADE
44	50016	3	SCREW	137	70591	1	KIT, FAN-PULLEY
46	50990	1	FILTER			3	SCREW, 1/4-20 X .75 LONG
49	51244	1	HEX LOCK NUT 1/2-20 (NYLON INSERT)			1	FAN, 6", 10 BLADE
50	50752	21	SCREW, 1/4-20 X .75 LONG			1	HEX LOCK NUT 1/2-20 (NYLON INSERT)
51	50744	1	14T BEVEL GEAR			1	PULLEY, 4.5
52	50745	1	19T BEVEL GEAR			1	HOSE/FITTING ASSEMBLY
53	50746	1	53T SPUR GEAR	138	70588	1	METAL FITTING
54	50757	1	INDTOR SHAFT			1	PINCH CLAMP, SINGLE EAR
						1	1/2" HOSE X 12.0" LONG