

5751  
312-2400L

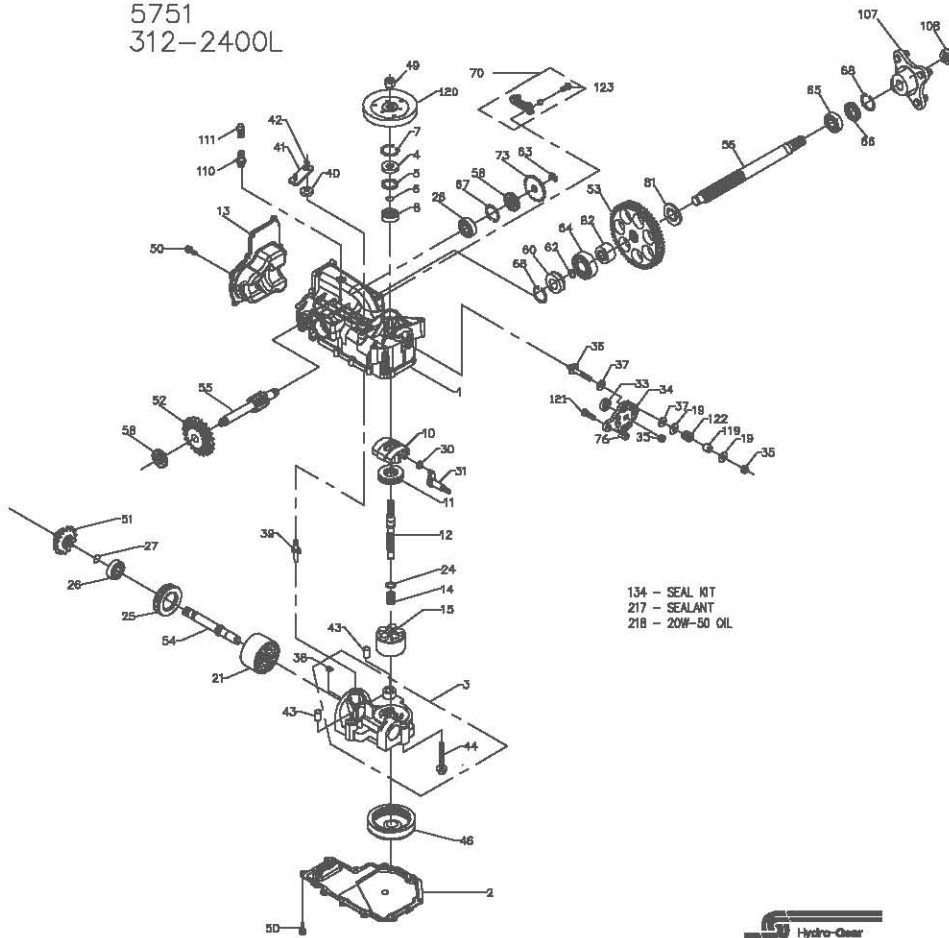

Hydro-Queen  
P.1 of 2. 70371L-P6

5751  
312-2400L

| ITEM # | PART #       | QTY | DESCRIPTION                 | ITEM # | PART #  | QTY   | DESCRIPTION                         |
|--------|--------------|-----|-----------------------------|--------|---------|-------|-------------------------------------|
| 1      | 70329        | 1   | UPPER HOUSING ASSEMBLY      | 52     | 50745   | 1     | 19T BEVEL GEAR                      |
|        |              | 1   | UPPER HOUSING               | 53     | 50746   | 1     | 53T SPUR GEAR                       |
|        |              | 2   | CRADLE BEARING              | 54     | 50757   | 1     | MOTOR SHAFT                         |
|        |              | 1   | TRUNNION BUSHING            | 55     | 70393   | 1     | BRAKE SHAFT KIT                     |
|        |              | 1   | LIP SEAL                    |        |         | 1     | RETAINING RING 0.440 EXTERNAL       |
| 2      | 50890RM      | 1   | LOWER HOUSING               | 56     | 50748   | 1     | AXLE SHAFT                          |
| 3      | 70667        | 1   | KIT, CENTER SECTION         | 58     | 50735   | 2     | SEAL, LIP 17 X 40 X 5               |
|        |              | 1   | CENTER SECTION              | 60     | 50995   | 1     | SEAL PLUG - SIDE                    |
|        |              | 1   | BUSHING .67 X 1.03 X .75    | 62     | 50758   | 1     | RETAINING RING - AXLE               |
|        |              | 1   | PLATE, BYPASS               | 63     | 70396   | 1     | RETAINING RING KIT                  |
|        |              | 3   | SCREW 3/8-24 X 2.5          | 64     | 50743   | 1     | BEARING-BALL 20X47X14(6204)         |
|        |              | 2   | CHECK PLUG ASSEMBLY, .027   | 65     | 50740   | 1     | BEARING-BALL 25X47X12(6005)         |
| 4      | 9008000-0128 | 1   | LIP SEAL                    | 66     | 50751   | 1     | SEAL                                |
| 5      | 2003018      | 1   | SPACER                      | 67     | 50329   | 1     | RETAINING RING                      |
| 6      | 2003016      | 1   | WIRE RETAINING RING         | 68     | 50760   | 2     | RETAINING RING-AXLE                 |
| 7      | 2003052      | 1   | RETAINING RING              | 70     | 70392   | 1     | RH. BRAKE ARM SERVICE ASSEMBLY      |
| 8      | 2003043      | 1   | BALL BEARING                |        |         | 1     | BRAKE ARM                           |
| 10     | 2003087      | 1   | VARIABLE SWASHPLATE         |        |         | 1     | CLEVIS PIN                          |
| 11     | 50551        | 1   | THRUST BEARING 30 X 52 X 13 |        |         | 1     | BUSHING 0.255X0.381X0.330           |
| 12     | 50005        | 1   | INPUT SHAFT                 |        |         | 1     | HEX WASHER HEAD SCREW, 1/4-20 X 7/8 |
| 13     | 50891RM      | 1   | COVER-BACK                  | 73     | 50754   | 1     | BRAKE DISC                          |
| 14     | 2003014      | 1   | SPRING, BLOCK               | 76     | 43063   | 1     | HEX NUT 5/16-18                     |
| 15     | 70331        | 1   | 10cc CYLINDER BLOCK ASS'Y   | 81     | 50942-2 | 1     | AXLE BUSHING                        |
|        |              | 1   | 10cc CYLINDER BLOCK         | 82     | 50942-1 | 1     | AXLE BUSHING                        |
|        |              | 5   | 10cc PISTON SPRING          | 106    | 70314   | 1     | HUB ASSEMBLY                        |
|        |              | 5   | PISTON SEAT WASHER          |        |         | 1     | HUB                                 |
|        |              | 5   | 10cc PISTON                 |        |         | 4     | LUG BOLT                            |
|        |              | 2   | WASHER                      | 108    | 50863   | 1     | NUT, HEX 3/4-16                     |
| 19     | 44130        | 1   | 21cc CYLINDER BLOCK ASS'Y   | 110    | 70110   | 1     | FITTING O-RING ASSEMBLY             |
| 21     | 70082        | 1   | 21cc CYLINDER BLOCK         |        |         | 1     | PLASTIC HOSE FITTING                |
|        |              | 7   | 21cc PISTON SPRING          |        |         | 1     | O-RING                              |
|        |              | 7   | PISTON SEAT WASHER          | 111    | 70109   | 1     | CAP VENT ASSEMBLY                   |
|        |              | 7   | 10cc PISTON                 |        |         | 1     | CAP-POPPET VALVE                    |
|        |              | 7   | WASHER, BLOCK THRUST        |        |         | 1     | PLASTIC VENT                        |
| 24     | 2003017      | 1   | THRUST BEARING 42 X 68 X 16 | 119    | 50278   | 1     | SPACER                              |
| 25     | 50552        | 1   | BALL BEARING                | 120    | 51182   | 1     | PULLEY, 4.5                         |
| 26     | 50315        | 2   | WIRE RETAINING RING         | 121    | 51047   | 1     | BOLT 5/16-18X1-1/4                  |
| 27     | 2000022      | 1   | SLOT GUIDE                  | 122    | 50277   | 1     | HELICAL COMP. SPRING                |
| 30     | 2000015      | 1   | TRUNNION ARM                | 123    | 51076   | 1     | HEX WASHER HEAD SCREW, 1/4-20 X 7/8 |
| 31     | 50807        | 1   | LIP SEAL                    | 134    | 70553   | 1     | KIT, SEAL                           |
| 33     | 9008000-0126 | 1   | CONTROL ARM                 |        |         | 1     | SEAL, LIP 15X35X7 PTC               |
| 34     | 50749        | 1   | NUT                         |        |         | 1     | RING, RETAINING                     |
| 35     | 50317        | 2   | STUD - LONG 5/16-24         |        |         | 1     | SEAL, LIP 12X25X7                   |
| 36     | 50284        | 1   | FRICITION PUCK              |        |         | 1     | SEAL, LIP 10X25X7                   |
| 37     | 50281        | 2   | KIT, BYPASS PLATE           |        |         | 1     | RING, RETAINING                     |
| 38     | 70680        | 1   | BYPASS ACTUATOR             |        |         | 1     | SEAL, LIP 17X40X7                   |
| 39     | 2003555      | 1   | LIP SEAL                    |        |         | 1     | SEAL, LIP 1.85X.32                  |
| 40     | 45074        | 1   | BYPASS ARM                  |        |         | 1     | RING, RETAINING                     |
| 41     | 50126        | 1   | RETAINING RING              |        |         | 1     | RING, RETAINING .440 EXTERNAL       |
| 42     | 44870        | 1   | PIN                         |        |         | 1     | SEAL, LIP .98X1.85X.278             |
| 43     | 50002        | 2   | SCREW                       |        |         | 1     | RING, RETAINING                     |
| 44     | 50016        | 3   | NUT-HEX HEAD JAM 1/2-20     |        |         | 2     | RING, RETAINING                     |
| 46     | 50890        | 1   | SCREW, 1/4-20, X .75 LONG   |        |         | 2     | SEAL, LIP 17X40X5                   |
| 48     | 44133        | 1   | 14T BEVEL GEAR              | 217    | 50928   | 1     | SEALANT                             |
| 50     | 50752        | 18  |                             | 218    |         | 77 oz | 20W-50 OIL                          |
| 51     | 50744        | 1   |                             |        |         |       |                                     |

Hydro-Queen  
P.2 of 2. 70371L-P6