

163611
218-2500

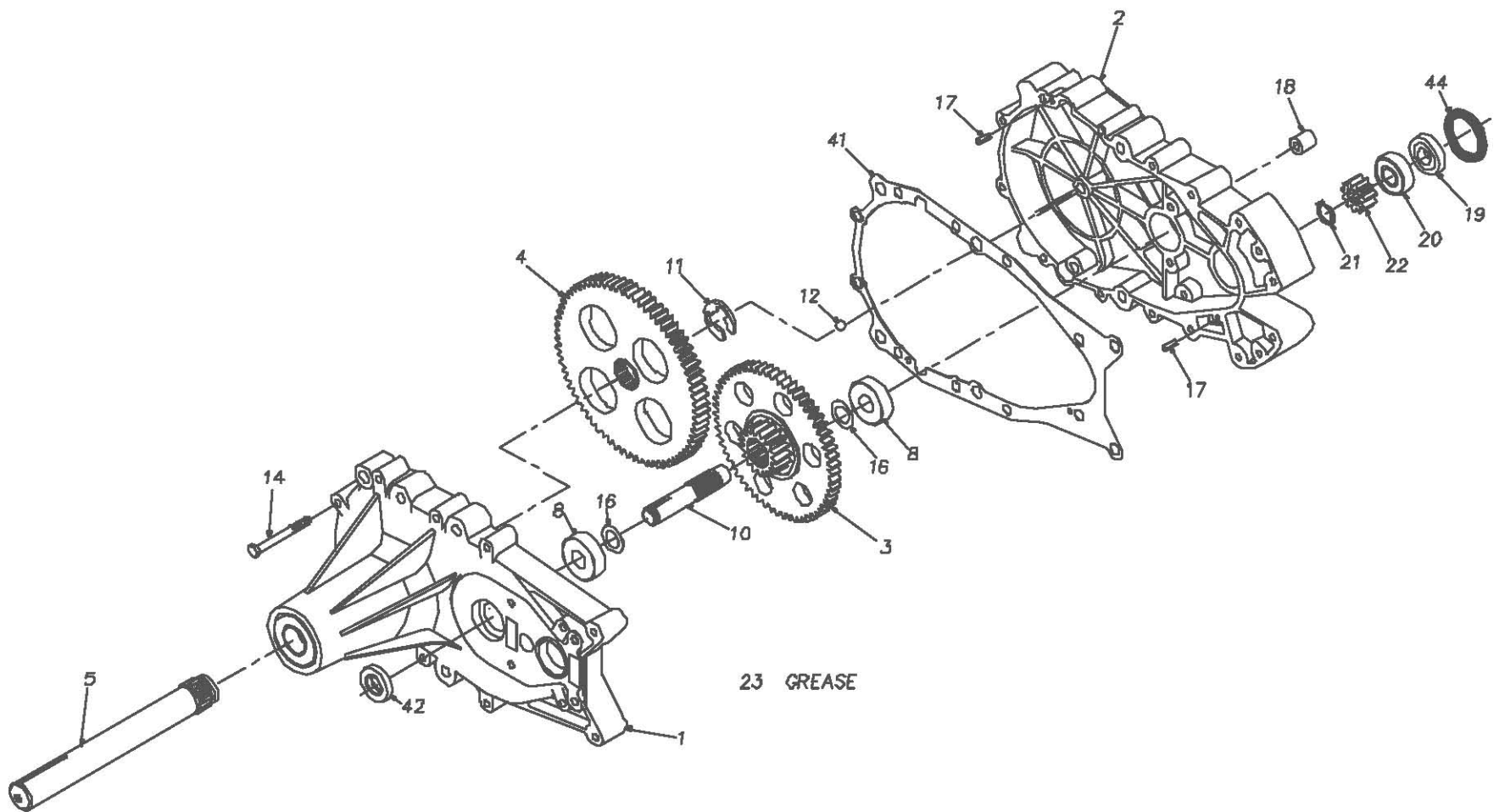

163611
218-2500

REF	PART NO.	QTY	DESCRIPTION
1	70272	1	ASS'Y, AXLE CARRIER HOUSING
		1	AXLE CARRIER HOUSING
		1	BALL BEARING, 52MM X 25MM X 15MM
		1	FLANGE BEARING
		1	OIL SEAL, 1.25 OD X .625 ID
		1	OIL SEAL, 52MM X 25MM
2	50904	1	HYDRO MOUNT HOUSING
3	44352	1	SPLINED REDUCTION GEAR
4	44358	1	SPLINED 72 TOOTH FINAL DRIVE GEAR
5	44709	1	AXLE SHAFT
8	50625	2	BALL BEARING .625ID X 1.57 X .47
10	44351	1	BRAKE SHAFT (SPLINED)
11	44359	1	E-RING
12	9001214-3700	1	BALL, 3/8" DIAMETER
14	44366	10	BOLT, 1/4-20 X 2-1/2"
16	50629	2	WASHER, 5/8ID X 1.0 OD X .01 THK
17	44269	2	PIN, SPRING 3/16" X 1/2" LONG
18	23749	3	MOUNTING SPACER
19	44355	1	BEARING SPACER
20	44232	1	BALL BEARING 15 MM X 35 MM X 11 MM
21	44354	1	RETAINING RING
22	44353	1	11 TOOTH INPUT GEAR
23	50416	2	GREASE (10 OZ TUBE)
41	50223	1	GASKET, HSG
42	50263	1	OIL SEAL, 1.25 X .625
44	50267	1	O-RING