



Wheel Horse®

**POWERED
TILLER**

**MODEL
WT-241**

*for all models
Wheel-Horse Tractors*

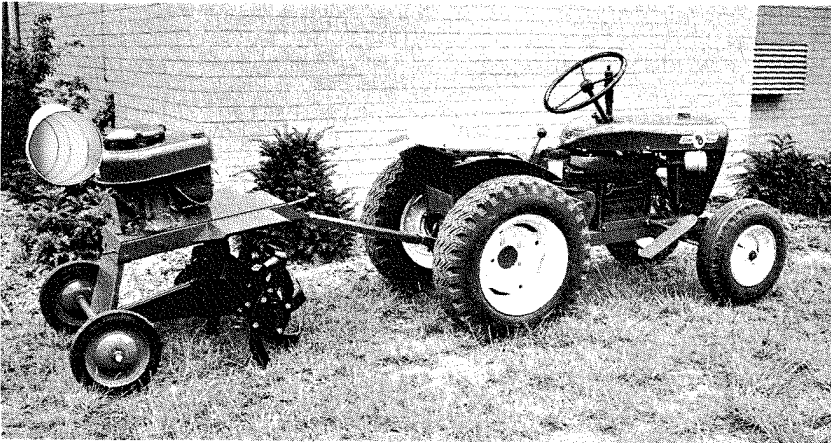
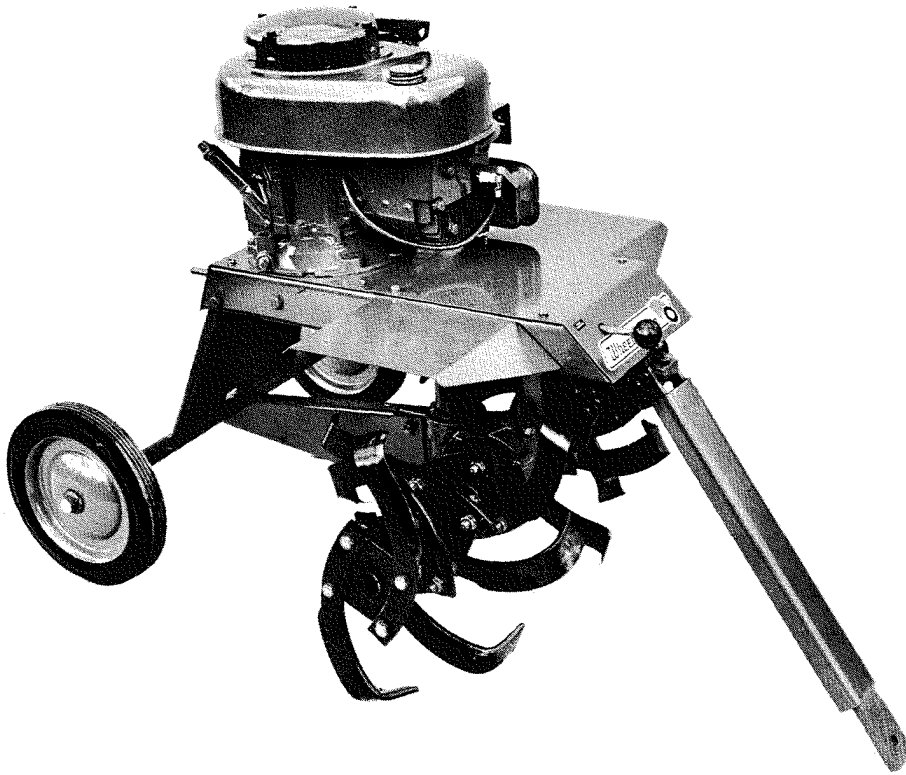

This tiller is the most advanced tractor-attaching tool ever produced. The tiller method of soil preparation and cultivation has fast become a favorite and a glance at the Wheel-Horse exclusives will quickly tell you "THIS IS THE ONE!"

SPECIFICATIONS

TILLING WIDTH—24".

TINES—16 Wheel-Horse exclusive design (pat. pending).

TILLING DEPTH—Up to 7" (depending on soil condition). Depth is controlled by speed of operation.

ENGINE—5½ h.p. vertical shaft with recoil starting.

WHEELS—Two 10-inch semi-pneumatic with leveling action.

DRIVE—Worm gear with tapered roller and needle bearings and Neoprene oil seals.

CLUTCH—Completely enclosed belt with spring loaded idler.

SHIPPING WT.—175 lbs.

Exclusive

FREE-FLOATING ACTION

eliminates tractor shock and protects tiller from damage by raising over foreign objects and re-adjusting to proper tilling depth automatically.

ATTACHES IN TEN SECONDS

to your tractor.
Simply lift tractor hitch pin, insert tiller tongue and replace pin.

Perfectly balanced for easy lift to travel position.

•
Handy clutch lever accessible from driver seat.

•
Packaged completely assembled, ready to go.



TILLER

MODEL

WT-241

ref. no.	part no.	description	no. req'd.	ref. no.	part no.	description	no. req'd.	ref. no.	part no.	description	no. req'd.
1	4300	Deck Assembly	1	26	1317	Hex Nut 7/16 - 14 Lock Nut	32	50	1626	Pulley 3" O. D. (Engine)	1
2	4322	Tine Tube Assembly	2	27	1133	Roll Pin 3/16 x 1	3	51	1627	Pulley 3" O. D. (Tiller Shaft)	1
3	4316	Clutch Arm Assembly	1	28	1149	Hex Hd. Cap Screw 7/16 - 14 x 1 1/4	32	52	1392	Shoulder Bolt	1
4	4313	Mounting Bar Assembly	1	29	1196	Shakeproof Lockwasher 5/16	3	53	1393	Stud - Control Rod	1
5	4310	Hitch Bar Assembly	1	30	1258	Hex Hd. Cap Screw 5/16 - 18 x 3 3/4	1	54	4000	Case - Tiller (Cast Iron)	1
6	4326	Pivot Tube Assembly	1	31	1302	Hex Jam Nut 1/2 - 20	1	55	4001	Plate - Cover (Cast Iron)	1
7	1396	Shim (Worm Gear)	1	32	1305	Hex Hd. Cap Screw 5/16 - 18 x 3	2	56	4002	Support (Cast Iron)	1
8	1397	Shim (Worm)	1	33	1332	Shakeproof Lockwasher 3/8	8	57	4003	Worm Gear	1
9	1122	Woodruff Key #9	2	34	1385	Hex Hd. Cap Screw W/Shake. Wash. 1/4 - 20 x 1/2	8	58	4004	Worm	1
10	1244	Roll Pin 1/8 x 1	1	35	1395	Woodruff Key #6	1	59	4005	Plate - End	1
11	4038	Gasket	1	36	1579	1/2" Belt 4L 24" (Heat Resist.)	1	60	4039	Gasket	2
12	1227	Roll Pin 3/16 x 1 3/4	1	37	1618	Idler Pulley	1	61	4040	Worm Shaft	1
13	1001	Shift Knob	1	38	1797	Engine (Lauson 5/5 H.P. Vertical Shaft	1	62	4041	Disc - Bearing Spacer	1
14	1002	Cotter Pin 1/8 x 1	5	39	1062	Hex Hd. Cap Screw 3/8 - 16 x 1	6	63	4063	Spacer - Lower	1
15	1007	Hex Nut 5/16 - 18	1	40	1039	Lockwasher 3/8	9	64	4032	Spacer - Tine	1
16	1014	Tension Spring	1	41	4320	Swivel Block	1	65	4064	Spacer - Upper	1
17	1015	Hex Hd. Cap Screw 3/8 - 16 x 1 3/4	2	42	4328	Axle	1	66	1515	Ball Bearing	1
18	1310	Lock Nut 3/8 - 16	9	43	4337	Wheels	2	67	1213	Oil Seal	3
19	1359	Hex Nut - Self Locking 3/8 - 16	1	44	4330	Tines R. H.	8	68	1526	Needle Bearing	2
20	1028	Hex Hd. Cap Screw 3/8 - 16 x 1 1/4	3	45	4331	Tines L. H.	8	69	1500	Cone - Bearing	1
21	1042	Soc. Hd. Set Screw Cup Pt. 5/16 - 18 x 5/16	3	46	4332	Rod - Clutch	1	70	1525	Cup - Bearing	2
22	1038	Flat Washer Wrought 5/8	1	47	4333	Top Plate - Rear	1	71	1299	Roll Pin 5/16 x 1 3/4	1
23	1061	Hex Hd. Cap Screw 3/8 - 16 x 3/4	4	48	4334	Cover - Tine	2	72	1237	Hex Hd. Cap Screw 1/4 - 20 x 5/8	10
24	1080	Hex Jam Nut 3/8 - 16	3	49	4308	Top Plate - Front	1	73	1113	Lockwasher 1/4	10
25	1093	Hex Hd. Cap Screw 3/8 - 16 x 2 1/2	2					74	1013	Pipe Plug Sq. Hd.	1

