

PARTS LIST AND INSTRUCTIONS

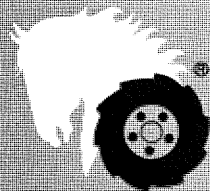

Wheel Horse

WHEELHORSE PRODUCTS, INC. - SOUTH BEND, IND.

54" DOZER BLADE

COMPLETING PACKAGE

MODEL

6-9611

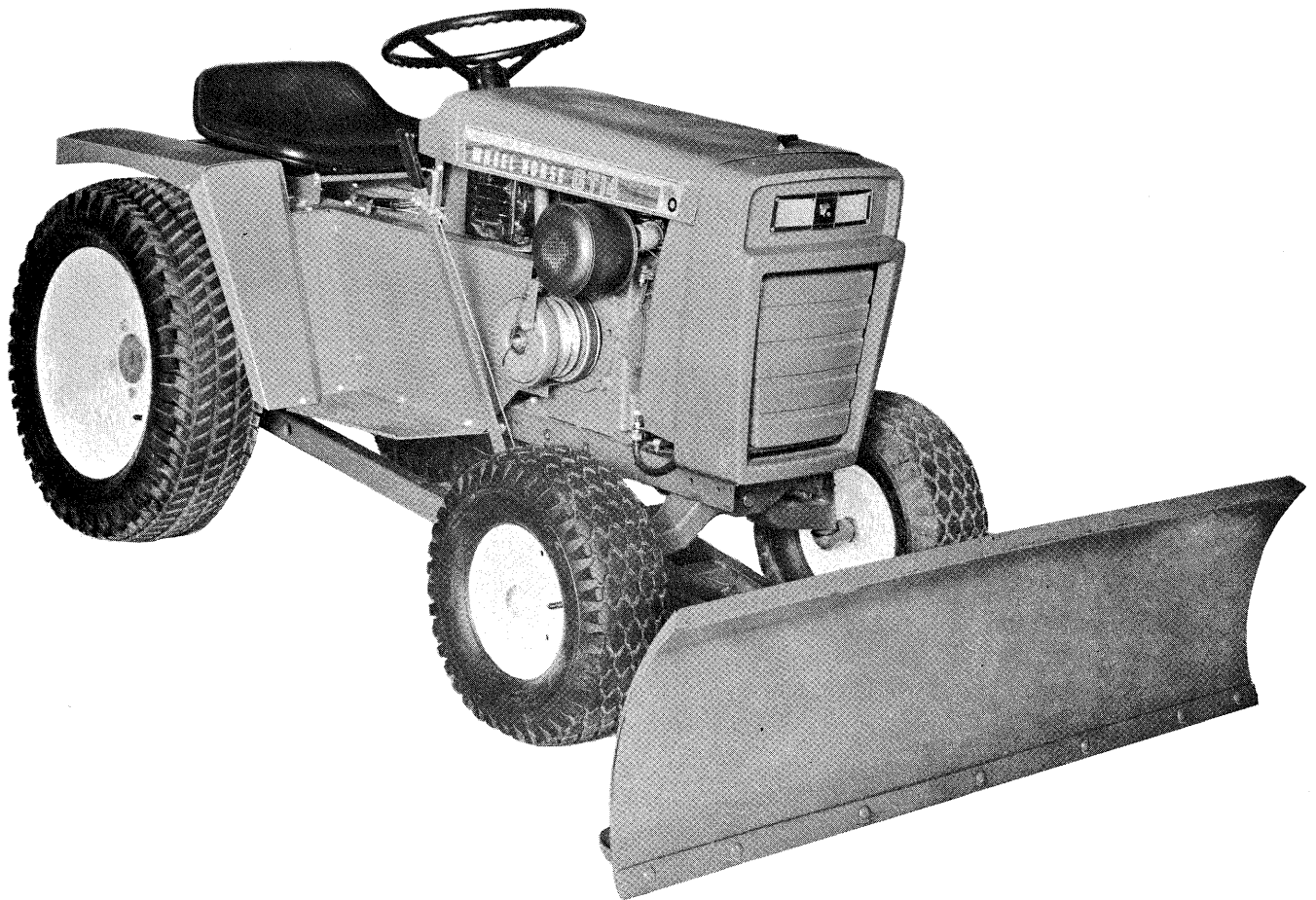

DESCRIPTION

The Dozer Blade is shipped in two separate cartons, a basic unit, and a completing package. This carton contains the completing package and must be used with the Basic Unit No. 6-4112.

ASSEMBLY AND MOUNTING

1. Install the mounting bracket assembly (see Fig. 1). The bracket should be centered on the axle housing. Secure in place with the links and $\frac{3}{8}$ -16 x $3\frac{1}{2}$ " carriage bolts and $\frac{3}{8}$ -16 elastic stop nuts.
2. Slide the frame assembly under the tractor. Insert the rear cross shaft on the frame assembly in the mounting bracket and latch. Be sure the index lever on the frame assembly is up before the frame is locked in position. See Fig. II. Note the cross shaft provided with the basic unit will have to be discarded and replaced with the cross shaft furnished in the completing package. Be sure to insert the cross shaft into the end hole of the frame assembly as shown in Fig. II.

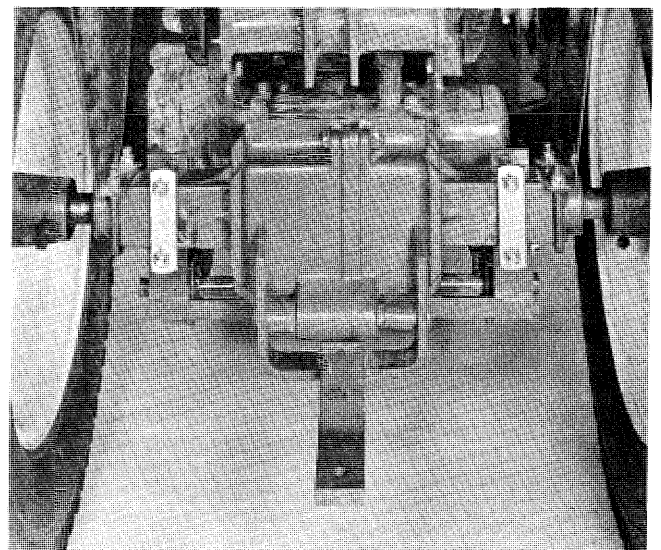

FIGURE I

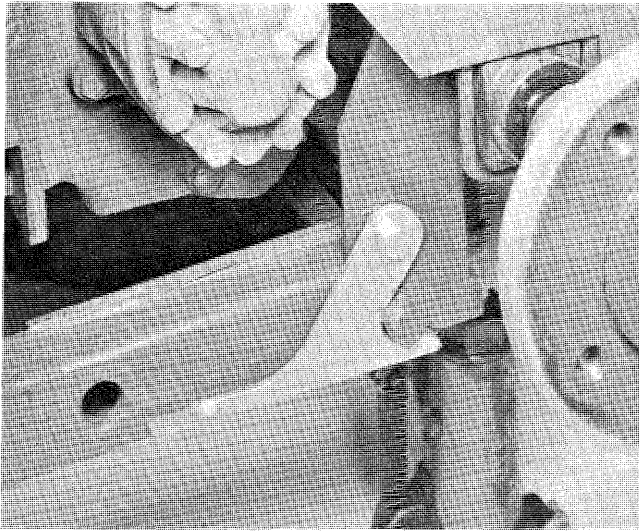

FIGURE II

3. Fit one end of the Lift Bar Part No. 8735 into the hole of the tractor lift arm. The lift arm that has the bent offset is the one used. The other end of the lift bar is inserted in the hole of the lift plate (not the slot) on the frame assembly.
4. The blade control rod, Part No. 5119, is inserted through the bottom of the pivot sector, and secured with hairpin cotter. Bolt the Pivot Sector, Part No. 5102, to the frame assembly using the Hex Bolt, Part No. 908256-4, and Part No. 915640-4, elastic stop nut. (NOTE: Apply a liberal coat of grease before installing.) Insert the bolt from the bottom and tighten, leaving it loose enough for the blade to swing free. See Fig. III. Attach the control rod to the control handle.
5. Attach the blade assembly to the pivot sector using Part No. 4564, lower pivot rod, and two $\frac{1}{8}$ " x 1" cotter pins, Part No. 932017-4. Next, install the two springs with the Pivot Rods, Part No. 5120. Fasten to the pivot sector first, with two of the hairpin cottes. Insert the other pivot rod in the blade angles. The angle of the blade will be determined by the hole in which the pivot rod is placed. For general use, the second hole down from the top is used. Tilt forward for earth spreading; tilt back for more aggressive action. See Fig. III.
6. Connect the wire rod from the assembly lever to the index plate. The bolt might have to be loosened to permit free movement of the plate.
7. A $\frac{3}{8}$ -16 x $8\frac{1}{2}$ " bolt, $7\frac{1}{16}$ " long spacer, and $\frac{3}{8}$ -16 nut is provided to limit the steering radius. This is installed to prevent the tire from rubbing on the frame assembly. The bolt is inserted into the fifth hole of the tractor frame. The spacer fits on the bolt between the frame rails. Secure in place with the $\frac{3}{8}$ -16 elastic stop nut. NOTE: The bolt spacer and nut is to be removed from the frame when the blade is not being used.
8. The skids, Part No. 2399, on each side of the blade must be adjusted before operation. This is accomplished by loosening the set screws, adjusting to the desired position, and tightening again. The purpose of the skids is to keep the blade from catching on cracks in the walk or drive, and to allow it to float over uneven surfaces.

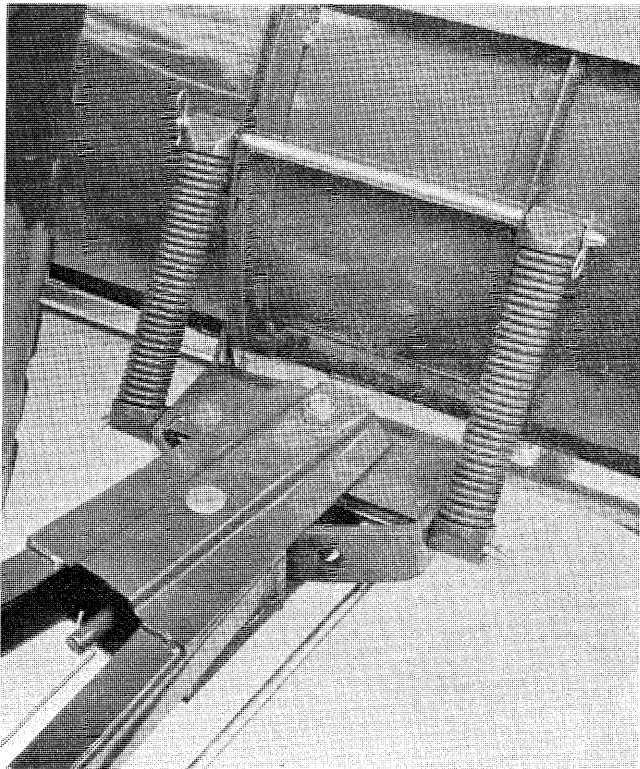

FIGURE III

OPERATION

This dozer is equipped with a spring trip device. If the blade should strike a solid object, it will tilt forward and slide over. The dozer blade is adjustable and may be locked in three different positions: straight, right angle, and left angle. These adjustments are easily accomplished from the tractor seat by operating the convenient turn lever. The blade is adjusted up and down with the lift lever.

Before operation, make sure that all bolts are tight and cotter pins opened. Excessive play in the pivot sector may be removed by tightening the large pivot bolt. The blade edge is reversible and replaceable. After the edge is worn, remove the bolts securing it to the blade and turn it over, providing a new cutting edge.

A light grade of machine oil should be applied to all moving parts, before operation, and after every 10 hours of use.

(CAUTION: Avoid hitting solid objects with the blade, as this could result in damage to the blade and injury to the operator.

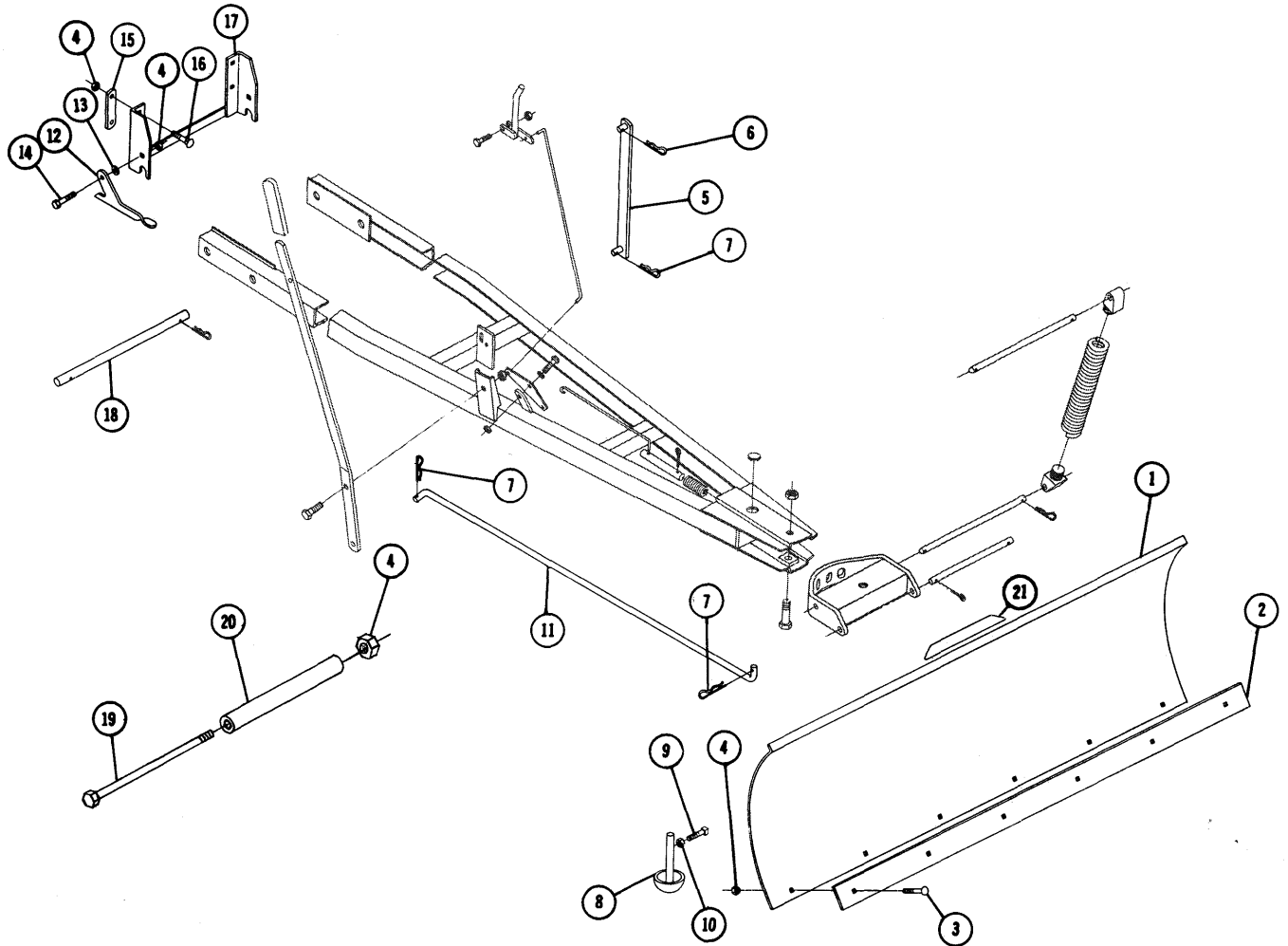

PARTS LIST FOR 54" DOZER BLADE COMPLETING PACKAGE MODEL 6-9611

(Specifications subject to change without notice.)

Item No.	Part No.	Description	No. Req'd.	Item No.	Part No.	Description	No. Req'd.
1	3070	Blade Ass'y	1	12	7704	Plate — Latching	2
2	3087	Plate — Blade Edge	1	13	920009-4	Washer $\frac{3}{8}$ SAE	2
3	900062-4	Bolt Carriage $\frac{3}{8}$ -16 x $\frac{3}{4}$	7	14	908034-4	Bolt Hex $\frac{5}{8}$ -16 x $1\frac{1}{2}$	2
4	915663-4	Nut $\frac{3}{8}$ -16 Elastic Stop	14	15	3697	Link	2
5	8735	Lift Bar	1	16	900073-4	Bolt — Carriage $\frac{3}{8}$ -16 x $3\frac{1}{2}$	4
6	933505-4	Hairpin Cotter	1	17	8010	Mounting Bracket Ass'y	1
7	933512-4	Hairpin Cotter	3	18	9189	Shaft Frame Mounting	1
8	2399	Skid Ass'y	2	19	900854-4	Bolt $\frac{3}{8}$ -16 x $8\frac{1}{2}$ Sq. HD.	1
9	909551-4	Set Screw $\frac{3}{8}$ -16 x $\frac{5}{8}$ Sq. HD.	2	20	9193	Spacer	1
10	915236-4	Nut $\frac{3}{8}$ -16 Hex Jam	2	21	5604	Decal	1
11	5119	Rod — Blade Control	1				