

Model No. Serial No.  
BD-426 (189054)

## PARTS LIST AND INSTRUCTIONS



*Wheel Horse*

WHEELHORSE PRODUCTS, INC. - SOUTH BEND, IND.

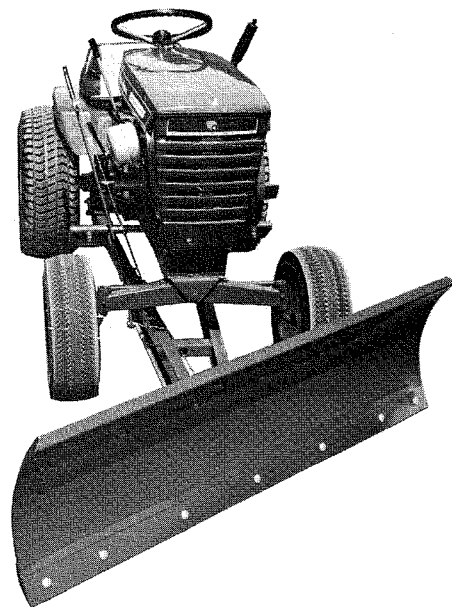
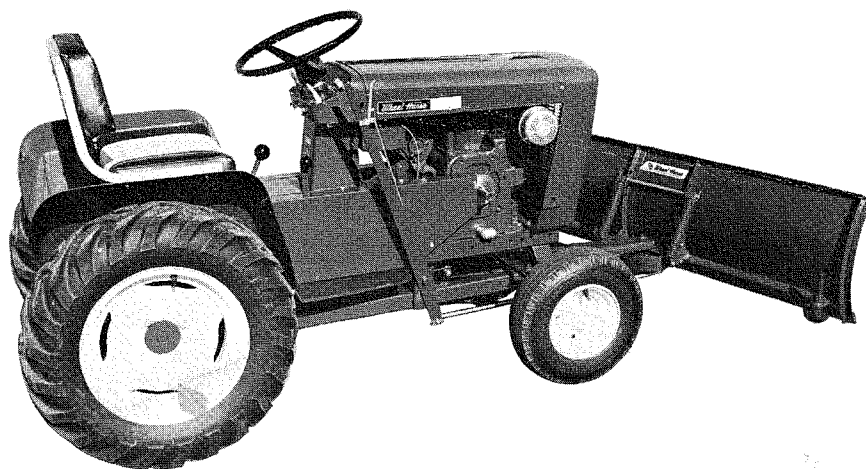

### ASSEMBLY AND MOUNTING

1. The BD-546 or BD-426 is shipped complete in one carton. There are three main parts in the carton. The Frame Assembly, Blade Assembly, and a box of parts.
2. Remove contents from carton and parts box.
3. Assemble rear mounting bracket assembly, Part No. 5145, using Part No. 3697 Link, 900072-4 Carriage Bolt, and  $\frac{3}{8}$ -16 Nylock Nuts. Install the R. and L. hand latching Plates using Part No. 900063-4 Carriage Bolt, spring washer, Part No. 3775, and Nylock Nut. The spring washer is installed under the nut. Adjust so that the latching plates are firm when in the latched position.
4. Slide the frame assembly, Part No. 3073, under the tractor. Insert the rear cross bar of the frame assembly in the mounting bracket and latch. Be sure the turn lever on the frame assembly is up and out of the way before the frame is locked in position.
5. Attach Lift Bar, Part No. 6410 (1076 - 1276 - 1056 tractors) or Lift Rod, Part No. ~~933512-4~~ (953 - 1054 tractors) to tractor lift arm. Secure with hairpin cotter, Part No. 933505-4. If your tractor uses Lift Bar (Part No. 6410) attach to dozer frame with clevis pin, Part No. 932124-4 and hairpin cotter, Part No. 933512-4 if your tractor uses Lift Rod (~~933512-4~~), ~~933512-4~~, Part No. 3086 and attach to dozer frame with clevis pin, Part No. 932124-4 and hairpin cotter, Part No. 933512-4.
6. Bolt the Pivot Sector, Part No. 5102, to the frame assembly using the Hex Bolt, Part No. 908256-4, and Part No. 915640-4, elastic stop nut. (NOTE: apply a liberal coat of oil before installing.) Insert the bolt from the bottom and tighten, leaving it loose enough for the blade to swing free.
7. Attach the Blade Assembly to the pivot sector using lower pivot rod, Part No. 4564, and two

## DOZER BLADE BD-546 and BD-426

$\frac{1}{8}$ " x 1" cotter pins, Part No. 932017-4. Next, install the two springs with the Pivot Rods, Part No. 5120. Fasten to the pivot sector first, with two of the hairpin cotters. Insert the other pivot rod in the blade angles. The angle of the blade will be determined by the hole in which the pivot rod is placed.

8. The blade control rod, Part No. 5119, is inserted through the bottom of the pivot sector, and through the back side of the lever. Secure with two hairpin cotters.

On 953 and 1054 tractors the blade should be adjusted so that the frame of the blade is locked tightly against the front axle of the tractor. This is done by adjusting the rod end on the lift rod.

9. ~~The skids, Part No. 2329 (BD-546), must be installed before operation. This is accomplished by loosening the set screws, adjusting to the desired position, and tightening again. The purpose of the skids is to keep the blade from catching on cracks in the walk or drive, and to allow it to float over uneven surfaces. (This dozer is equipped with a spring trip device. If the blade should strike a solid object it will tilt forward and slide over without jarring the operator.)~~

### OPERATION

The dozer blade is adjustable and may be locked in three different positions: straight, right angle, and left angle. These adjustments are easily accomplished from the tractor seat by operating the convenient turn lever. The blade is adjusted up and down with the tractor lift.

A light grade of machine oil should be applied to all moving parts, before operation, and after every 10 hours of use.

(CAUTION: Avoid hitting solid objects with the corners of the blade as this could result in damage.)

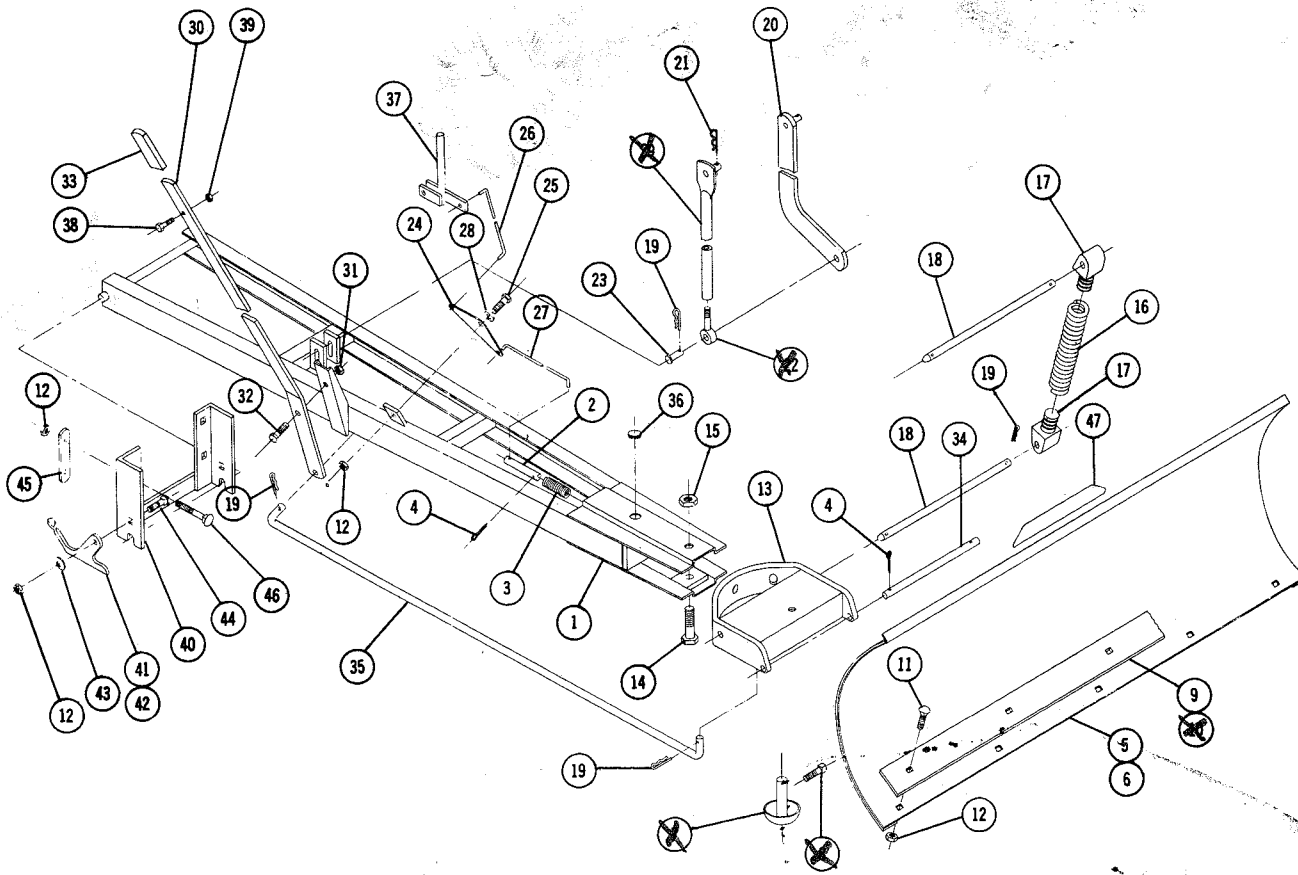

## PARTS LIST

When ordering parts always list Part No. and name of part.

Ref. No.	Part No.	Description	No. Req'd. BD-546	No. Req'd. BD-426	No. Ref.	Part No.	Description	No. Req'd. BD-546	No. Req'd. BD-426
1	3073	Ass'y. Frame	1	1	25	908035-4	Bolt — Hex 3/8-16 x 1 1/4	1	1
2	5127	Pin — Index	1	1	26	3772	Rod — Upper Index	1	1
3	2354	Spring	1	1	27	3771	Rod — Lower Index	1	1
4	932017-4	Cotter Pin 1/8 x 1	3	3	28	920009-4	Washer 3/8 SAE	1	1
5	5109	Ass'y. Blade	0	1	<del>29</del>	<del>4595</del>	<del>Ass'y. Rod End Lift</del>	<del>1</del>	<del>0</del>
<del>6</del>	<del>3070</del>	<del>Ass'y. Blade</del>	<del>1</del>	<del>0</del>	30	6411	Lever — Index	1	1
<del>7</del>	<del>2399</del>	<del>Ass'y. Skid</del>	<del>2</del>	<del>0</del>	31	915238-4	Nut Hex 1/2-13 Jam	1	1
<del>8</del>	<del>909551</del>	<del>Set Screw Square Hd. 3/8-16 x 3/8</del>	<del>2</del>	<del>0</del>	32	908057-4	Bolt Hex 1/2-13 x 1	1	1
9	2346	Plate — Blade Edge	0	1	33	5359	Grip	1	1
<del>10</del>	<del>3007</del>	<del>Plate — Blade Edge</del>	<del>1</del>	<del>0</del>	34	4564	Rod — Lower Pivot	1	1
11	900062-4	Bolt Carriage 3/8-16 x 3/4	7	5	35	5119	Rod — Blade Control	1	1
12	915663-4	Nut 3/8-16 Elastic Stop	14	12	36	4944	Plug Button	2	2
13	5102	Ass'y. Sector & Channel	1	1	37	5107	Ass'y. Lever	1	1
14	908256-4	Bolt Hex 3/4-16 x 3 3/4	1	1	38	908005-4	Bolt Hex 1/4-20 x 1	1	1
15	915640-4	Nut Hex 3/4-16 Elastic Stop	1	1	39	915111-6	Nut Nylock 1/4-20	1	1
16	5117	Spring — Trip Return	2	2	40	5145	Ass'y. Bracket Mtg.	1	1
17	5125	Lug	4	4	41	5135	Plate — Latching R.H.	1	1
18	5120	Rod — Trip	2	2	42	5136	Plate — Latching L.H.	1	1
19	933512-4	Hairpin	7	7	43	3775	Washer — Spring	2	2
20	6410	Ass'y. Lift Bar	1	1	44	900063-4	Bolt — Carriage 3/8-16 x 1	2	2
21	933505-4	Hairpin	1	1	45	3697	Link	2	2
<del>22</del>	<del>3006</del>	<del>Rod — End</del>	<del>1</del>	<del>0</del>	46	900072-4	Bolt — Carriage 3/8-16 x 3 3/4	4	4
23	932124-4	Pin — Clevis 1/2 Dia.	1	1	47	5604	Decal — Attachment	1	1
24	3770	Plate — Index	1	1					